

**EFFECT OF MERGERS ON CAPITAL STRUCTURE OF A FIRM: A CASE  
OF NATIONAL INDUSTRIAL CREDIT BANK (K) LTD**

**BY  
JOSEPH KIPROTICH TUWEI**

**A THESIS SUBMITTED IN PARTIAL FULFILMENT OF THE  
REQUIREMENTS FOR THE AWARD OF DEGREE IN MASTER OF BUSINESS  
MANAGEMENT, SCHOOL OF BUSINESS AND ECONOMICS, MOI  
UNIVERSITY**

**JUNE, 2013**

**DECLARATION**

**By the student**

I declare that this thesis is my original work and has not been submitted for examination in any university.

Name: Joseph Kiprotich Tuwei

Reg. No: SBE/PGM/027/10

Signature..... Date.....

**By the supervisors**

This thesis has been submitted for examination with our approval as university supervisors.

Dr. Joel Tenai

Senior Lecturer, Department of Accounting and Finance

School of Business and Economics

Moi University

Signature..... Date .....

Dr. Julius K. Bitok

Senior Lecturer, Department of Accounting and Finance

School of Business and Economics

Moi University

Signature..... Date .....

## **DEDICATION**

This study is dedicated to my family for their support and encouragement they gave me during the entire period of my study and thesis writing.

## **ACKNOWLEDGEMENT**

I wish to acknowledge the Almighty God for the strength and grace during the period of my study. I sincerely thank my supervisors Dr. Joel Tenai and Dr. Julius Bitok for their support and guidance during the entire period of the research who ensured that I carry out the study successfully. I acknowledge Dr. David Koskei and Dr. Tarus for their guidance in this thesis writing. I also appreciate my friends Ezekiel and Moses for their support.

**LIST OF ABBREVIATIONS**

NIC:	National Industrial Credit bank Limited
CBK:	Central Bank of Kenya
NPV:	Net Present Value
IT:	Information Technology
USA:	United States of America
NSE :	Nairobi Stock Exchange
DOL :	Degree of Operating
DFL :	Degree of Financial Leverage
AM Bank:	African Mercantile Bank Limited

## ABSTRACT

Mergers in Kenya banking industry have grown dramatically since 1994. Some of the reasons put forward for mergers are to meet the increased levels of share capital, market share, firm size, information asymmetry, tax regimes, and to benefit from best global practices among others. The banking industry is consolidating at an accelerating pace yet no conclusive results have emerged on the benefits of mergers. This study sought to establish the effect of mergers on capital structure, using the case of NIC Bank Ltd. The specific objective was to establish the relationship between the bank's capital structure and its bad loans, size, services and interbank. The study adopted an explanatory research design since it is a cause-effect relationship. It used secondary data from the Nairobi Stock Exchange (NSE). Both descriptive and inferential statistics were used to analyze the data. Regression analysis showed that firm size affected capital structure most ( $\beta_2=0.940$ , p value = 0.002), followed by bad loans ( $\beta_1=0.894$ , p value = 0.004) and bank services ( $\beta_3=0.641$ , p value =0.000). Interbank affected capital structure negatively ( $\beta_4= -0.511$ , p value=0.003). The study concludes that mergers increased positively the effect of firm size, services and bad loans on capital structure while interbank affected capital structure negatively. The study recommends firms in the banking industry to plan and evaluate mergers while focusing on effects of firm size, bad loan, income from services and net interbank on its capital structure.

## TABLE OF CONTENTS

DECLARATION.....	ii
DEDICATION .....	iii
ACKNOWLEDGEMENT.....	iv
LIST OF ABBREVIATIONS .....	v
ABSTRACT .....	vi
TABLE OF CONTENTS .....	vii
LIST OF TABLES .....	ix
LIST OF FIGURES .....	x
DEFINITION OF TERMS .....	xi
<b>CHAPTER ONE.....</b>	<b>1</b>
<b>1.0 INTRODUCTION .....</b>	<b>1</b>
1.1 Background of the Study .....	1
1.2 Statement of the Problem .....	5
1.3 Research Objectives .....	6
1.3.1 General objective. ....	6
1.3.2 Specific Objectives.....	6
1.4 Research Hypotheses.....	6
1.5 Significance of the Study.....	6
1.6 Scope of the Study.....	7
<b>CHAPTER TWO.....</b>	<b>9</b>
<b>LITERATURE REVIEW .....</b>	<b>9</b>
2.0 Introduction .....	9
2.1 Concept of Firm’s Capital structure .....	9
2.1.2 Static Trade off Theory .....	14
2.2 Concept of Mergers .....	16
2.3 Mergers and Capital Structure.....	21
2.3.1 Bad Loans and Capital Structure.....	25
2.3.2 Firm Size and Capital Structure .....	29
2.3.3 Income from Services and Capital Structure .....	32
2.3.4 Net Interbank and Capital Structure.....	34
2.4 Conceptual frame work .....	38

<b>CHAPTER THREE.....</b>	<b>40</b>
<b>RESEARCH METHODOLOGY.....</b>	<b>40</b>
3.0 Introduction .....	40
3.1 Research Design .....	40
3.2 Target Population .....	40
3.3 Sampling Size and Procedure .....	40
3.4 Data Collection Method .....	41
3.5 Data Analysis.....	41
3.6 Model Specification.....	42
3.7 Limitations of the Study .....	42
3.8 Ethical Considerations.....	43
<b>CHAPTER FOUR .....</b>	<b>44</b>
<b>DATA ANALYSIS, PRESENTATION AND INTERPRETATION .....</b>	<b>44</b>
4.0 Introduction .....	44
4.1 Descriptive Statistics .....	44
4.2 Pre and Post Merger Correlation Analysis .....	53
4.3 Regression Analysis of Bad Loan, Services, Interbank and Firm Size against Capital Structure .....	57
4.3.1 Effect of bad loan on capital structure before and after merger.....	58
4.3.2...Effect of income from services on capital structure before and after the merger	60
4.3.3 Effect of interbank on capital structure before and after merger .....	60
4.3.4 Effect of firm size on capital structure before and after the merger .....	61
<b>CHAPTER FIVE.....</b>	<b>62</b>
<b>SUMMARY OF FINDINGS, CONCLUSION AND RECOMMENDATION .....</b>	<b>62</b>
5.0 Introduction .....	62
5.1 Summary of Findings .....	62
5.2 Conclusion.....	64
5.3 Recommendations .....	65
5.3.1 Policy recommendations .....	65
5.3.2 Recommendations for Further Study .....	66
<b>REFERENCES .....</b>	<b>67</b>
<b>APPENDIX I: DOCUMENTARY ANALYSIS GUIDE.....</b>	<b>75</b>



**LIST OF TABLES**

Table 4.1: Descriptive Statistics (Means Differences).....	50
Table 4.2: Descriptive Statistics for Variables .....	52
Table 4.3: Pre and Post Merger Correlation Analysis .....	54
Table 4.4: Regression Analysis.....	57

**LIST OF FIGURES**

Fig 2.1: Conceptual Framework .....	38
Fig 4.1: Distribution of total asset.....	44
Fig 4.2: Distribution of Total equity .....	45
Fig 4.3: Distrubution of Total lending .....	45
Fig 4.4: Distribution of Gross income .....	46
Fig 4.5: Distribution of Income from Services .....	47
Fig 4.6: Distribution of Bad Loan.....	48
Fig 4.7: Distribution of Interbank .....	49

## DEFINITION OF TERMS

**Capital structure** -Capital structure refers to the way an organization finances its assets through some combination of equity, debt or hybrid securities.

**Synergy**- synergy may be defined as two or more agents working together to produce a result not obtainable by any of the agents independently. In the context of organizational behavior is the view that a cohesive group is more than sum of its parts. Synergy is the ability of group to outperform even its best individual member, Pandey (2005).

**Merger**- A merger occurs when a previously independent bank loses its charter and becomes part of an existing bank, with one headquarters and a unified branch network.

**Capital base** -This is the issued capital of a company, that is, the money contributed by the shareholders who first acquired shares in the company, plus reserves and retained profits. Capital base is also considered the capital structure of a company shareholders' capital plus loans and retained, Peek and Rosengren (2000).

## **CHAPTER ONE**

### **1.0 INTRODUCTION**

This chapter presents the background of the study, the statement of the research problem, the research objectives, research hypothesis, significance of the study and the scope of the study.

#### **1.1 Background of the Study**

Mergers are widely used technique to increase the rate of growth, size and market share of a firm. Some scholars claim the merger decision is related to capital structure, where the post-merger leverage can increase tax benefits and therefore the firm's value, Lewellen (1971). The relationship between capital structure and merger decisions is still not well understood. There are a few recent articles, for instance Morellec and Zhdanov (2008) Margrabe (1978) who presented an early example of modeling mergers as an exchange option with exogenous timing, dynamic model of takeovers with two bidders, endogenous leverage and bankruptcy. Their model supports the empirical evidence that the bidders winning the contest have leverage below the industry average.

Leland (2007) derives a model where only financial synergies motivate the merger decision. He claims that the magnitude of this effect depends on the firm's characteristics like default costs, firm size, taxes, and riskiness of cash flows. Hege and Hennessy (2010) present an analysis where the level of debt plays a strategic role in benefiting from larger merger share. However, there exists a trade-off between higher surplus and the resulting debt overhang which precludes efficient mergers.

Morellec and Zhdanov (2008) predict that leverage is reduced before the merger and increased afterwards as a result of an option exercise game between bidding and target shareholders and Harford *et al.* (2009) find that firms adjust their capital structures before mergers if they are overleveraged.

The assumption that a firm cannot acquire a firm that is larger than it implies that a firm can reduce its chance of being acquired by acquiring another firm. This increases its size, which then reduces the number of other firms that are potential acquirers. There are fewer firms that are sufficiently large. In fact, empirically it has been found that the probability of being a target in an acquisition is decreasing in a firm's size (Hasbrouck (1985), Palepu (1986), Ambrose and Megginson (1992)). In the first scenario only profitable acquisitions occur (the "efficient" scenario). In the other scenario (the "eat-or-be-eaten" scenario) defensive, unprofitable acquisitions that preempt some profitable acquisitions occur. Which scenario arises depends on the incentives of managers to make defensive acquisitions. If managers are less interested in remaining independent (and gaining the associated private benefits) than in maximizing shareholder value (because their compensation depends on it), there is no defensive merger pressure. No firm will acquire another firm if perceived unprofitable, and hence all mergers lead to positive returns for both the target and the acquirer.

However, if managerial desire not to be acquired is sufficiently strong, then the merger dynamics change dramatically. Now managers are tempted to engage in defensive acquisitions to secure the independence of their firms perhaps well before the regime

shift has made the acquisitions profitable. This defensive merger motive is self-reinforcing: Because some managers feel the need to secure the independence of their firms by making defensive acquisitions, other managers are driven to protect the independence of their own firms by making defensive acquisitions themselves. Defensive mergers come in waves. Where a firm has an efficient profitable acquisition opportunity in the future, several other firms may be induced to engage in defensive acquisitions to ensure their survival as independent firms Richard (2006).

According to DePamphilis and Donald (2008) firms may merge if a regime shift makes mergers profitable, and a potential target firm may acquire another firm to become large enough to deter the takeover offer. Hence, several firms all potential takeover targets may each attempt to make a defensive acquisition, and each firm's defensive acquisition makes the other firms more likely to be left as the most attractive target if they do not themselves engage in a defensive acquisition. Hence, the potential profitable acquisition opportunity for one firm can lead to an "eat or be eaten" merger wave. In this case, there are more mergers than in the absence of managerial defensive motives, they occur too early, and the acquirers lose money. Even though a regime shift (of a technological or regulatory nature) may, in principle, allow profitable acquisitions, it can have the effect of inducing a defensive wave of unprofitable acquisitions. If many firms are of similar size, the defensive merger waves of unprofitable acquisitions discussed above are likely if managers care enough about staying in control, that is, private benefits are high. However, if the largest firm with a profitable acquisition opportunity (Firm 1) is much larger than the other firms in the industry, the merger dynamics are very different. Now no firm can defend itself against acquisitions by Firm 1 by acquiring another firm.

Indeed, acquiring other firms has the opposite effect of making the firm larger, and hence a more attractive takeover target (if synergies are increasing in the target firm's size). If managers care enough about preserving the independence of their firms, they avoid acquisitions. But, if managers care a lot about firm value, that is, private benefits are low, they may engage in acquisitions of other firms in order to become larger and hence a more attractive target (for the firm with profitable acquisition opportunities).

NIC was incorporated in Kenya on 29th September 1959, when Standard Bank Limited and Mercantile Credit Company Limited (Mercantile) -both based in the United Kingdom – jointly formed the company. The company was amongst the first non-bank financial institutions to provide hire purchase and installment credit finance facilities in Kenya.

NIC became a public company in 1971 and is currently quoted on the Nairobi Stock Exchange with approximately 21,000 shareholders. Barclays Bank of Kenya Limited acquired 51% of NIC's total shares through the acquisition of Mercantile in the 1970s and Standard's shareholding in NIC in the 1980s. Between 1993 and 1996, BBK divested its shares, selling 38% of its shares to the public in 1994, and the remaining 20% in 1996 to the First Chartered Securities Group (FCS).

This study sought to examine whether a merger of NIC Bank and African Mercantile Bank Limited (AM Bank) is related to changes in its capital structure of the two merged banks. The purpose was to find out whether there is a cause-effect relationship between the merger and its capital structure. This study was aimed at analyzing specific empirical evidence from the developing countries like Kenya which is crucial since the developed

economies experiences cannot be automatically applied to the undeveloped environment in general and Kenyan economy in particular.

## **1.2 Statement of the Problem**

Firms have various motives for entering into mergers. These motives range from reducing market competition, cutting costs, reducing taxes, removing management, to empire building. Recent years have seen the emergence of merger waves worldwide in financial institutions and studies on its effects have concentrated on areas like firm performance, shareholders value, profitability, employees, management, and payment among others. It is apparent that researchers have placed little emphasis on the impact of synergies of mergers on firm's capital structure and so the scanty literature on this study. Much of the literature available on effects of mergers on capital structure merely relate but not so direct to the study. For instance, Agliardi *et al*, (2013) argued that firms with less correlated activities, higher growth options, lower volatilities of cash flows and lower bankruptcy costs have higher capital structure, decrease capital structure before the merger and increase capital structure after the merger. However, there is dearth of similar studies in developing countries like Kenya.

In view of the inadequate research in the banking industry on effects of mergers on capital structure, this study investigates the relationship between bad loan, firm size, income from services, net interbank and capital structure in the context of merger, using the case of NIC bank merger from 1998 to 2010.



### **1.3 Research Objectives**

#### **1.3.1 General objective.**

To establish the effects of bank merger on capital structure

#### **1.3.2 Specific Objectives.**

- i. To determine the effect of bad loan on a banks' capital structure
- ii. To determine the effect of firm size on a banks' capital structure
- iii. To determine the effect of income from services on a banks' capital structure
- iv. To determine the effect of net interbank on a banks' capital structure

### **1.4 Research Hypotheses**

The study focuses on testing the following research hypothesis

**H<sub>01</sub>.** There is no significant effect of bad loan on a banks' capital structure

**H<sub>02</sub>.** There is no significant effect of firm size on a banks' capital structure

**H<sub>03</sub>.** There is no significant effect of income from services on a banks' capital structure

**H<sub>04</sub>.** There is no significant effect of net interbank on a banks' capital structure

### **1.5 Significance of the Study**

The study explores the effects of bank mergers on its capital structure and gives the analysis of both pre and post merger results of the bank merger. The study provides a body of knowledge to investors, bank managers, economic and financial analysts, researchers and academicians on the general trend of financial institutions mergers and its effects on capital structure. It enables banking industry in developing countries like

Kenya to appreciate the whole process of mergers, the scale and pace of merger activity. During periods of merger activity, the financial manager spend significant amounts of time either searching for firms to acquire or worrying about whether some other firm will acquire his or her company. This study encourages bank managers to understand why banks could merge and be able to know the motives for mergers, benefits and mechanics for mergers and its effects on capital structure. The motives for mergers range from entering a new market, introducing new products through research and development, achieving administrative benefits, increased market share, lower cost of operation and/or production, gaining higher competitiveness, industrial positioning, financial leveraging, improving profitability in addition to value addition and efficient cost reduction and management. The study also proposes other areas of interest to a finance researcher to explore further on effects mergers of firms in other industries like hotels tours and travel industry, farming industry, manufacturing industry among others. Researchers who are doing related study may use this research as their secondary data. The benefit of the study was that firms management may use the outcome to improve on its operation and hence performances, provide information to firms who intend to do merger and to investors on how mergers affect capital structure thus good decision making. The study also provides information to investors, researchers and students in this field and it showed the gaps requiring the need for pursuing further studies in this area.

### **1.6 Scope of the Study**

The study analyses both pre and post merger results of NIC bank and AM bank merger in 1998. This was intended to investigate effects of bad loan, size of firm, net interbank and

income from services of NIC bank on its capital structure as a result of merger. The unit of analysis was NIC Bank in Kenya focusing on a merger of the financial institution and effects on its capital structure. The research analyzed the financial reports of NIC bank and AM bank before and after the Merger between 1995 to 2010 and established the impact of the merger on its capital structure. The study was carried out from January to February 2012.

To analyze the merger, the balance sheets of NIC Bank and AM Bank are involved throughout the whole period studied so as to consider them as a single bank from the beginning. A Proforma balance sheet is computed by consolidating the balance sheets of the merging banks involved throughout the period. This was to determine how mergers affected the firm's capital structure. The research avoided the years 1998 to 2004 being the transitional period. During the period there was a lot excitement and abnormal behavior in the market. Further information was obtained from internet based articles and reports mostly on the NIC Merger, Kenya annual list report (2010).

## CHAPTER TWO

### LITERATURE REVIEW

#### 2.0 Introduction

This chapter discusses the literature review of the study. Literature review helps in identifying the relevant theories addressing the research problem, concept of mergers, concept of capital structure, the relationship between mergers in terms of bad loan, firm size, income from services and net interbank loans and capital structure.

#### 2.1 Concept of Firm's Capital structure

Kyereboah *et al* (2007) defined capital structure as the relative amount of debt and equity used in financing the operations of a firm. Boateng (2004) provides a definition of the capital structure as a ratio of total debt to total assets at book value. In dispelling the Modigliani and Miller theory, Boateng (2004) concludes by pointing how much the capital structure matters in reality, especially in cases where banks have to finance projects with debt capital. Flynn *et al* (2006) refer to optimal capital structure as, debt-equity ratio that is applied by a company to have the lowest Weighted Average Cost of Capital (WACC).

The importance of the capital structure as a measure of company growth and performance has been at the core of vigorous debate for many years. With the threat of the recession and global competitiveness to the survival of organizations, what constitutes an optimal capital structure had to be interrogated, Mgudlwa (2001).

Research suggests that a firm's survival, especially in very difficult circumstances, capital structure is essential for growth and performance, Asteriou *et al* (2004).

Lambrechts (1990) simplifies capital structure by referring to as the liability side of the balance sheet, made up of the shareholders interest and the borrowed capital of a firm. Interestingly the same authors use the term Financing Structure interchangeably to capital structure, suggesting the composition of forms of financing in terms of the required ratio between debt and shareholders interest. The author advances aspects to be considered when financing policy guidelines are formulated. This includes differentiation between shareholder capital and debt as financing forms, differentiation between fixed and current assets as well as permanent and variable capital requirements, limitations of the discussion on the management of manufacturing industry as public companies and profitability, liquidity, solvency and control. The concept is extremely important because it influences not only the return a company earns for its shareholders, but whether or not a firm survives in a recession or depression.

Broadly speaking, there are two forms of capital, equity capital and debt capital and each has its own benefits and drawbacks. Management attempts to find the optimum capital structure in terms of risk - reward pay-off to its shareholders. Equity capital refers to money put up and owned by the shareholders. Typically, equity capital consists of contributed capital, which is the money that was originally invested in the business in exchange for shares of stock and retained earnings, which represents profits from past years that have been kept by the firm and used to fund growth, acquisitions or expansion.

Debt capital in a firm's capital structure refers to borrowed money that is at work in the business, Flynn *et al* (2006).

In a company, it is the directors who are so called elected representatives of equity shareholders. These members have got maximum voting rights in a concern as compared to the preference shareholders and debenture holders. Preference shareholders have reasonably less voting rights while debenture holders have no voting rights. If the company's management policies are such that they want to retain their voting rights in their hands, the capital structure consists of debenture holders and loans rather than equity shares, Myers (2003).

In an enterprise, the capital structure should be such that both contractions as well as relaxation are in plans. Debentures and loans can be refunded back as the time requires while equity capital cannot be refunded at any point which provides rigidity to plans. Therefore, in order to make the capital structure possible, the company should go for issue of debentures and other loans.

The Company's policy generally is to have different categories of investors for securities. Therefore, a capital structure should give enough choice to all kind of investors to invest. Bold and adventurous investors generally go for equity shares and loans and debentures are generally raised keeping into mind conscious investors.

During the depression period, the company's capital structure generally consists of debts and loans. In periods of boom and inflation, the company's capital should consist of share capital generally equity shares. When company needs to raise finance for short period, it goes for loans from banks and other institutions while for long period it goes for issue of shares and debentures.

In capital structure, the company looks to the factor of cost when raising security. It is seen that debentures at the time of profit earning of company prove to be a cheaper source of finance as compared to equity shares where equity shareholders demand an extra share in profits.

An established business which has a growing market and high sales turnover, the company is in position to meet fixed commitments. Interest on debentures has to be paid regardless of profit. Therefore, when sales are high, thereby the profits are high and company is in better position to meet such fixed commitments like interest on debentures and dividends on preference shares. If company is having unstable sales, then the company is not in position to meet fixed obligations. So, equity capital proves to be safe in such cases.

Small size business firm's capital structure generally consists of loans from banks and retained profits. While on the other hand, big companies having goodwill, stability and an established profit can easily go for issuance of shares and debentures as well as loans and borrowings from financial institutions. The bigger the size, the wider is total capitalization.

The Modigliani-Miller theorem, proposed by Franco Modigliani and Merton Miller (1958), forms the basis for modern thinking on capital structure, though it is generally viewed as a purely theoretical result since it disregards many important factors in the capital structure decision. The theorem states that, in a perfect market, how a firm is financed is irrelevant to its value. This result provides the base with which to examine real world reasons why capital structure is relevant, that is, a company's value is affected by the capital structure it employs. Some other reasons include bankruptcy costs, agency costs, taxes, and information asymmetry. This analysis can then be extended to look at whether there is in fact an optimal capital structure, the one which maximizes the value of the firm.

Modigliani and Miller (1963) made two findings under capital structure in a perfect market. Their first proposition was that the value of a company is independent of its capital structure. Their second proposition stated that the cost of equity for a leveraged firm is equal to the cost of equity for an unleveraged firm, plus an added premium for financial risk. That is, as leverage increases, while the burden of individual risks is shifted between different investor classes, total risk is conserved and hence no extra value created. Their analysis was extended to include the effect of taxes and risky debt. Under a classical tax system, the tax deductibility of interest makes debt financing valuable; that is, the cost of capital decreases as the proportion of debt in the capital structure increases. The optimal structure then would be to have virtually no equity at all. If capital structure is irrelevant in a perfect market, then imperfections which exist in the real world must be the cause of its relevance.



The modern theory of capital structure began with the ground breaking theory of Modigliani and Miller (1958). MM posits that capital structure is irrelevant to value of the firm. According to Rajan and Zingale (1995), we now understand the most important departures from the Modigliani and Miller hypothesis that make capital structure relevant to a firms' value. However, the determinants of debt finance remain elusive despite a vast theoretical literature and decades of empirical tests. 'There is no universal theory of capital structure and no reason to expect one. However, there are useful conditional theories.... Each factor could be dominant for some firms or in some circumstances yet unimportant elsewhere, Myers (2003).

### **2.1.2 Static Trade off Theory**

The static trade-off theory of capital structure (also referred to as the tax based theory) states that optimal capital structure is obtained where the net tax advantage of debt financing balances leverage related costs such as financial distress and bankruptcy, holding firm's assets and investment decisions constant Baxter, (1967 and Altman (2002). In view of this theory, issuing equity means moving away from the optimum and should therefore be considered bad news. According to Myers (1984), firms adopting this theory could be regarded as setting a target debt-to-value ratio with a gradual attempt to achieve it. Myers (1984), however, suggests that managers will be reluctant to issue equity if they feel it is undervalued in the market. The consequence is that investors perceive equity issues to only occur if equity is either fairly priced or overpriced. As a result investors tend to react negatively to an equity issue and management is reluctant to issue equity. Static Trade-off theory, centers on the repayment and costs of issuing debt,

predicts that an attractive target debt ratio is to make the paramount value of the company. The best point can be accomplished when the marginal value of the payback is linked with debt concerns exactly offsets the raise in the present value of the costs correlated by handing out more debt Myers, (2001). The main benefit of debt is the tax deductibility of interest payments. The tax deduction of corporate interest payments favors the application of debt. It will be more with the existence of personal taxes, Miller (1977) and non-debt tax protection, DeAngelo and Masulis (1980).

Corporate managers have the incentive to misuse free cash flow on perquisites and bad investment. Debt financing confines the free cash flow available to the manager's commitment settling the interest and principal and by this means efficient control of the firms' financial difficulties. The costs associated with issuing debt are the costs of financial distress. Modigliani and Miller, (1963) and the firm costs is triggered by conflicts between shareholders and debtors which was indicated by Ozkan (2001), that costs of financial distress will arise when a firm uses many unnecessary debt and is powerless to meet the interest and principal payments. The trade-off theory entails a target adjustment model. In the model, firms contain a target debt ratio in which they slowly adjust. The debt is adjusted by comparing the ratio of debt in the preceding period with the predetermined target debt ratio. The adjustment, though, is only partial because of the market imperfections such as transaction costs highlighted by Marsh, (1982) and adjustment costs and constraints as indicated by Jalilvand and Harris (1984). If firms are as above the target debt ratio the worth of the firm is not the best because financial distress and company costs go beyond the benefits of debt. Therefore, we expect firms

that are higher than their target debt ratio, to reduce their debt. Firms that have a debt ratio below the target debt ratio increase the value of the firm because marginal value of the benefits of debt is still greater than the costs connected with the use of the debt. Durinck. L, Van H and Vandembroucke, (1998), highlighted that the cost and benefits of debt made the corporations target debt ratio to exploit their debt in the best effort and firms that.

## **2.2 Concept of Mergers**

Merger refers to the combining of two or more companies, generally by offering the stockholders of both companies, securities in the merging company in exchange for the surrender of their stock. Basically, when two companies become one, this decision is usually mutual between both firms. In the pure sense of the term, a merger happens when two firms, often of about the same size, agree to go forward as a single new company rather than remain separately owned and operated. This kind of action is more precisely referred to as a "merger of equals." Both companies' stocks are surrendered and new company stock is issued in its place. For example, both Daimler-Benz and Chrysler ceased to exist when the two firms merged, and a new company, DaimlerChrysler, was created. Companies get into mergers due to dozens of reasons some of which include reduced running costs which are achieved through actions such as staff reductions, economies of scale and improved market reach among others. There exist a variety of mergers such as horizontal mergers where two companies that are in direct competition and share the same product lines and markets come together to form one company, Pearl (2009).

Vertical mergers occur when a supplier and company come together for instance a corn supplier comes together with an ice cream maker. When two companies which sell the same products in different markets come together to broaden their market reach, the resultant merger is called a market-extension merger. A product extension merger is witnessed when two companies selling different but related products in the same market come together. Another type of merger occurs when two companies whose business areas are not related at all come together to form one, this is referred to as conglomeration, Pearl (2009). Brealey Myers (2000) asserted that mergers are often categorized as horizontal, vertical, or conglomerate. Horizontal merger is one that takes place between two firms in the same line of business. A vertical merger involves companies at different stages of production. The buyer expands backward toward the source of raw materials or forward in the direction of the ultimate consumer. A conglomerate merger involves companies in unrelated lines of business.

The motives for mergers are varied as and often lead the way to real benefits, though sometimes are mirages that tempt unwary or overconfident managers into takeover disasters. Economies of Scale are the natural goal of horizontal mergers. But such economies have been claimed in conglomerate mergers, too. The architects of these mergers have pointed to the economies that come from sharing central services such as office management and accounting, financial control, executive development, and top-level management, Pandey (2005).

Some companies try to gain control over the production process by expanding back toward the output of the raw material and forward to the ultimate consumer. One way to achieve this is to merge with a supplier or a customer. Vertical integration facilitates coordination and administration.

Many small firms are acquired by large ones that can provide the missing ingredients necessary for the small firms' success. The small firm may have a unique product but lack the engineering and sales organization required to produce and market it on a large scale. The firm could develop engineering and sales talent from scratch, but it may be quicker and cheaper to merge with a firm that already has ample talent. The firms have complementary resources—each has what the other needs—and so it may make sense for them to merge. The firms are worth more together than apart because each acquires something it does not have and gets it cheaper than it would by acting on its own. Also, the merger may open up opportunities that neither firm would pursue otherwise (Koetter, 2007).

Sometimes a firm may have potential tax shields but not have the profits to take advantage of them. For example, after its bankruptcy and reorganization, Penn Central had billions of dollars of unused tax-loss carry-forwards. It subsequently purchased Buckeye Pipeline and several other mature, taxpaying companies so that these carry-forwards could be used.

A firm that is generating a substantial amount of cash, but it has few profitable investment opportunities may ideally distribute the surplus cash to shareholders by increasing its dividend payment or repurchasing stock. Unfortunately, energetic managers are often reluctant to adopt a policy of shrinking their firm in this way. If the firm is not willing to purchase its own shares, it can instead purchase another company's shares. Firms with a surplus of cash and a shortage of good investment opportunities often turn to mergers financed by cash as a way of redeploying their capital. Some firms have excess cash and do not pay it out to stockholders or redeploy it by wise acquisitions. Such firms often find themselves targeted for takeover by other firms that propose to redeploy the cash for them (Stulz, 1988).

In some instances better management may simply mean the determination to force painful cuts or realign the company's operations. Acquisition is simply the mechanism by which a new management team replaces the old one. Managers are naturally reluctant to fire or demote themselves, and stockholders of large public firms do not usually have much direct influence on how the firm is run or who runs it. Acquisition often precedes a change in the management of the target firm. Managers of a cash-rich company may prefer to see it use that cash for acquisitions rather than distribute it as extra dividends. That is why cash-rich firms in stagnant industries merge their way into diversified and reduced risk.

Lower Financing Costs. When firms merge, they can borrow at lower interest rates than either firm could separately. While the firms are separate, they do not guarantee each other's debt; if one fails, the bondholder cannot ask the other for money. But after the merger each enterprise effectively does guarantee the other's debt; if one part of the business fails, the bondholders can still take their money out of the other part. Because these mutual guarantees make the debt less risky, lenders demand a lower interest rate.

A number of earlier studies have analyzed mergers and acquisitions financing decisions. Hansen (1987), Stulz (1988) and Fishman (1989) developed theories of acquisition payment choice based on asymmetric information. Of these studies only Stulz's focuses primarily on corporate control concerns. He points that mergers and acquisitions financing decisions are affected by management's desire to maintain corporate control and generate continued personal benefits. Eckbo *et al* (1990) developed an asymmetric information model that predicts that the revealed bidder value is monotonically increasing and convex in the fraction of the total offer that consists of cash. In their model a mix of debt and cash is chosen to convey information about the bidder's true value. Hansen (1987) finds that bidders have greater incentives to finance with stock when the asymmetric information about the target asset is high.

The work is also related to the wide and growing empirical literature considering mergers and acquisitions processes and the impact of capital and ownership structure on the method of payments. Faccio and Masulis (2005) study the payment choices of the mergers and acquisitions in Europe for the period 1997-2000. Their primary focus is the

tradeoff between bidder corporate control threats which discourage stock financing and bidder financing constraints. They find that corporate control incentives to choose cash are particularly strong when a bidder's controlling shareholder has an intermediate level of voting power. They find that European bidders choose stock financing with greater frequency as measures of their financial condition weaken Andrade, Mitchell and Stafford (2001) claim that the theory has limited success of explaining why mergers might occur. While Faccio and Masulis find that most European bids are entirely cash financed Andrade *et al.* Faccio and Masulis (2005) report that 80% of the European MAs are pure cash deals, 8.4% are mix of cash and stock and 11.3% are pure stock deals.

### **2.3 Mergers and Capital Structure**

Capital structure decisions may become relevant and, in addition, may be influenced by the expansion of growth opportunities in mergers that merging firms tend to decrease leverage just before the merger and increase leverage significantly in the years after the merger. Moreover, we find that this effect is stronger for merging firms that are less correlated, have significantly larger growth options, lower bankruptcy costs and lower volatility consolidation via mergers reduces risk and thus increases potential leverage allowing for greater financial benefits (Lewellen 1971). Leland (2007) shows that this diversification effect may not always be positive, with the sign of the financial benefits affected by factors such as the volatility and bankruptcy costs of the two firms and the level of the correlation of the firms' cash flows.



Clayton and Ravid (2002), Leary and Roberts (2005) and Harford et al. (2009) find that firms adjust their capital structures before mergers if they are overleveraged firms maximize their firm values by mergers and acquisitions when they reduce the leverage deficit effectively after the transactions. In the process of mergers and acquisitions, the method of payment is also an important factor that can influence the acquiring firm's capital structure.

Harford, Klasa, and Walcott (2007) move one step further and analyze how the deviations from target capital structure influence the financing method in these acquisitions. They find that overleveraged firms are more likely to finance these acquisitions with equity instead of debt. In the debt financing acquisitions, they find that acquiring firms move closer to their target level of leverage within five years. Therefore, their evidence supports the existence of target capital structures.

In the review of the capital structure literature, Harris and Raviv (1991) noted that it is generally accepted that firms in a given industry will have similar leverage ratios while leverage ratios vary across industries. Long and Malitz (1985), and Kester (1986) investigated leverage ratios for selected industries. These studies all found that specific industries have a common leverage ratio which, over time, is relatively stable. Hamada (1972), using industry membership as a proxy for risk class, found that levered beta values within different industries varied more than unlevered beta values. He concluded that there was a relationship between the cost of equity and financial leverage. DeAngelo, Masulis (1980) and Masulis (1983) use the documentation of this industry effect as one

argument for the presence of an industry-related optimal capital structure and imply that it is the tax code and tax rate differences across industries that cause the inter-industry similarities in leverage ratios.

The correlation of capital structure to industry membership and/or the DeAngelo-Masulis differential tax arguments have received empirical support in Schwartz and Aronson (1967), Scott and Martin (1975), Scott (1972), Bowen, *et al*, (1982), Cordes and Sheffrin (1983), and Ben-Horim *et al*, (1987). However, not all of the evidence is unanimous in its support. Boquist and Moore's (1984) findings did not support the tax shield hypothesis at the firm level; however, they did find weak evidence in support of the theory at the industry level.

They, however, like other researchers, found that total leverage varies across industry groupings. In addition to the tax shield hypothesis that explains the large body of empirical evidence relating industry membership and leverage, other arguments may relate industry membership to capital structure decisions. Lev (1974) compared operating leverage to industry membership and to systematic risk and found a positive relationship. Building on Lev's study, Mandelker and Rhee (1984) derived the relationship between beta and both operating leverage and financial leverage. They concluded that the conjecture that firms engage in trade-offs between DOL and DFL seems to have gained strong empirical evidence in our study.

Since industry, to a large degree, influences production processes and therefore operating leverage, and if there is a tradeoff in DOL and DFL as found by Mandelker and Rhee (1984), a firm's industry may have some influence on its capital structure decisions. Specifically, if firms attempt to keep combined leverage at a manageable level, and, if DOL is impacted by industry membership, then firms in an industry with a high DOL may carry less debt while firms in an industry with low DOL may carry more debt. In addition, earnings variability is influenced by DOL and DFL. Bradley, Jarrell and Kim (1984) find that the volatility of earnings is a strong inverse determinant of debt. To the extent that earnings volatility may be industry related, this may also affect the relationship between industry membership and capital structure decisions.

Individual firms and industries can be characterized by their growth rates. Rapidly growing firms (and industries) have a surfeit of positive net present value projects while slow-growth firms may have an excess of cash. Jensen and Meckling (1976) suggest that a particular capital structure can result from using debt as a monitoring and controlling device for managers. Further developing the free cash flow argument, Jensen (1986) points out that slow growth firms will have large amounts of excess cash that managers may decide to use for The determination of Optimal capital structure personal perquisites and other non-positive net present value projects.

If the firm issues debt, then the manager will own an increasing percentage of the firm's stock. Furthermore, excess cash will be reduced, and the debt covenant and bondholders will act as monitoring and controlling agents over the manager's behavior. Following

JM's and Jensen's arguments, low growth firms (and their industries) should demonstrate increasing debt levels in their capital structure.

The main focus is on the change of shareholders wealth after Merger. Bruner (2002) surveys many related research results and find that target firms' shareholders earn positive market return but those of acquiring firm earn around zero abnormal return. The sum of market returns from Merger activities, however, is still positive. In addition, Harford (2005) tries to identify the reason of merger waves. He finds that one very important reason for the merger clustering in time is sufficient overall capital liquidity, which implies lower financial constraint or transaction costs. Combining both findings, we expect that firm's capital structure should play an important role in the merger activities. Specifically, we are interested in the interaction between Merger and acquiring firm's capital structure. We also expect that the characteristic of capital structure could explain part of the difference of the effect of merger.

### **2.3.1 Bad Loans and Capital Structure**

The term "bad loans" as described by Basu (1998), is used interchangeably with non-performing and impaired loans as identified in Fofack (2005). Berger and De Young, (1997) also considers these types of loans as "problem loans". Thus these descriptions are used interchangeably throughout the study.

Generally, loans that are outstanding in both principal and interest for a long time contrary to the terms and conditions contained in the loan contract are considered as non-performing loans. This is because going by the description of performing loans above, it

follows that any loan facility that is not up to date in terms of payment of both principal and interest contrary to the terms of the loan agreement, is nonperforming.

Fofack (2005) in his study asserted that, almost all these institutions are crippled with lot of inefficiencies, bad loans and poor recovery of loans. But variables like provisions for bad loans which differ from bank to bank due to differences in credit risk will have impact on profits and P-E ratios. Since banks are dealing with a variety of financial services, the asset portfolios are differing from one bank to the other. For example, one bank may be focusing more on retail lending and another may be exposed to corporate lending. The risk-return characteristics of portfolios of these two banks are different and it is difficult to compare earnings and price-multiples of these two banks. In some countries like Germany, weak banks were forcefully merged to avoid the problem of financial distress arising out of bad loans and erosion of capital funds (see for example Berger *et al.*, (1999) for an excellent literature review). Economist argues that the risk of banks' bad liabilities spreading to other industries as a result to merger could further worsen the situation in the banking system.

Research findings and publications show that bad loans occur as a result of some factors. Berger and De Young (1997) identified poor management as one of the major causes of problem loans. They argue that managers in most banks with problem loans do not practice adequate loan underwriting, monitoring and control. Salleo (2002), who analyze the determinants of merger for a sample that covers the 1985-1996 periods. the impact of bad loans should already be captured at least in part by profitability, which is measured

net of charge-offs. By controlling for profitability, the risk variable in effect measures the impact of unexpected losses.

A World Bank policy research working paper on Non-performing Loans in Sub-Saharan Africa revealed that bad loans are caused by adverse economic shocks coupled with high cost of capital and low interest margins, Fofack (2005). Goldstein and Turner (1996) stated that “the accumulation of non-performing loans is generally attributable to a number of factors, including economic downturns and macroeconomic volatility, terms of trade deterioration, high interest rate, excessive reliance on overly high-priced inter-bank borrowings, insider lending and moral hazard”. Some writers also hold the view that bad loans can be caused by problem accounts. Rouse (1989) indicated in his work that problem loans can emanate from overdrawn account where there is no overdraft limit, overdraft taken on an account which has not been actively operated for some time and overdraft taken in excess of reasonable operational limits. He also identified lack of good skills and judgment on the part of the lender is a possible cause of bad loans. Bloem and Gorter (2001) indicated that non-performing loans may rise considerably due to less predictable incidents such as the cost of petroleum products, prices of key export products, foreign exchange rates or interest rates change abruptly. They also stated that deficient bank management, poor supervision, overoptimistic assessments of creditworthiness during economic booms, and moral hazard that result from generous government guarantees are some of the factors that lead to bad loans.

A possible effect of bad loans is on shareholders earnings. Dividends payments are based on banks performance in terms of net profit. Thus since bad loans have an adverse effect on profitability of banks, it can affect the amount of dividend to be paid to share holders. The economic crisis has brought problems for many Kenyan financial institutions. As borrowers default on loans, bank revenues suffer and this impair their capital structure. Banks mostly finance the loans they make with debt (such as deposits). Banking regulations require them to maintain adequate capital. This means that, to protect a bank's creditors against its insolvency, the bank must reserve a portion of its capital against each loan it makes. As a result, a bank cannot make more loans than it can support by its capital.

Additionally, when a borrower falls behind on loan payments (and the loan thus becomes a bad asset or bad loan), the bank must set aside some of its revenue to provide against a potential loss. That revenue is not counted towards profits of the bank. As a result, when too many loans are not repaid on time, a bank finds itself in a financial double bind. On the one hand, it may be forced to report a loss as its revenue is eaten up by loan loss provisions. At the same time, the bank cannot boost the revenue by making new loans because it lacks the capital to support them. As the bank's solvency suffers, it may become a target of various regulatory measures, ranging from increased capital requirements to the suspension of operations. Unless corrective action is promptly taken, the bank's position will deteriorate and it may end up in bankruptcy.

The standard way to deal with the problem is to recapitalize the bank, normally by the injection of new share capital. But doing so is not always possible or practicable. Besides,

increasing share capital does not by itself address the core problem: the bank's bad loans. Generally, fixing the bad asset problem is, in the first instance, all about mitigating a bad situation, not profiting from it. Almost invariably a loss will be incurred, a price of the bad judgment in making the loan. The challenge for a bank is how to get rid of bad loans with minimal cost and, if possible, recapture whatever residual value the loans may still have. Assets with no inherent value (e.g. unsecured consumer loans) are probably best sold to a collection company. On the other hand, mortgages and corporate loans collateralized by potentially valuable assets may hold inherent value that can potentially be preserved and realized. Overall, however, this approach may be optimal in that it achieves three concurrent objectives: get the bank recapitalized, remove bad loans from the bank, and preserve the loans' residual value for the bank's shareholders. An alternative is often either abandoning the bank to insolvency or keeping papering over the problem until it explodes. Neither is, obviously, an attractive option.

### **2.3.2 Firm Size and Capital Structure**

Wheelock and Wilson (2004) found that expected merger activity in US banking was positively related to management rating, bank size, competitive position and geographical location of banks and negatively related to market concentration. Substantial gains from mergers are expected to come from cost savings owing to economies of scale and scope. In a survey of US studies, Berger and Humphrey (1994) concluded that the consensus view of the recent scale economy literature is that the average cost curve has a relatively flat U-shape with only small banks having the potential for scale efficiency gains and usually the measured economies are relatively small. To achieve the benefit of low



capital requirements, small size banks would be required to consolidate themselves to become large. In line with this, RBI (2001) observed that, the new Basel Accord, when implemented, is expected to have far-reaching implications such as further consolidation through mergers and acquisitions.

Empirical research, Kishan and Opiela (2000), Pandit *et al.* (2006) shows that large size banks are more capable than others to offset shocks arising out of monetary policy induced decrease in deposits or increase in cost of funds, because they can fund borrowings (other than deposits) more easily. These findings highlight the need for forming large banks through consolidation.

In an industry in which some but not all firms are of a similar size, medium-size firms have both the opportunity to make defensive acquisitions (that make them large enough to be protected from takeovers) as well as positioning acquisitions (that make them more attractive takeover targets). In these industries, the pattern of mergers depends crucially on firm size and the level of managerial private benefits. It shows that the profitability of acquisitions is generally decreasing in the acquirer's size. Large firms engage only in defensive, unprofitable acquisitions, many articles in the press or trade journals mention the idea that if firms do not make acquisitions, they may become targets themselves.

These mixed firm size industries are most likely to exhibit merger waves, because some firms have defensive as well as positioning merger motives. Which motive matters depends on their managers' interest in maximizing firm value. While the additional

acquisitions may not be undertaken by medium-size firms, those firms tend to make the most acquisitions in industries with economies of scale, firm size becomes the driving force for merger dynamics. Often, this leads to profitable acquisitions. However, if a firm becomes very large and its manager's private benefits are high, it may engage in an unprofitable defensive acquisition, Focarelli, Panetta, and Salleo (2003).

Since an important ingredient to our theory is the size of potential acquirers and targets, it has also predictions on the quality of acquisitions undertaken by firms of different size. There is a negative correlation between acquirer returns and acquirer size because large firms are more likely to engage in defensive acquisitions than small firms. More specifically, our theory implies that large firms tend to make negative NPV acquisitions (leading to negative abnormal returns), medium size firms both positive and negative NPV acquisitions, and small firms positive NPV acquisitions. In such industries, the only acquisitions that large firms undertake (with the exception of the largest firm) are of defensive nature, and they occur if private benefits are high (if private benefits are sufficiently low, they do not make any acquisitions), Focarelli, *et al*, (2002).

The effect of relative size of target and acquirer depends on the size of the acquirer. It shows that for medium sized firms, the ratio of target to acquirer size is negatively correlated with acquirer returns. This arises because medium sized firms acquire relatively large firms for defensive purposes if private benefits are high but relatively small firms in positioning mergers if private benefits are low. In contrast, for small

acquirers, we conjecture that the ratio of target to acquirer size and the acquirer's abnormal returns are positively correlated.

### **2.3.3 Income from Services and Capital Structure**

According to Jayedev (2001) to provide integrated financial services and to improve efficiency and gain competitive positioning, some public sector banks have acquired their own subsidiaries. Similar acquisitions took place in private sector as well mergers. Here, it may be noted that many public sector banks have already consolidated their financial services by merging their own subsidiaries with parent banks.

Since banks are dealing with a variety of financial services, the asset portfolios are differing from one bank to the other. For example, one bank may be focusing more on retail lending and another may be exposed to corporate lending. The risk-return characteristics of portfolios of these two banks are different and it is difficult to compare earnings and price-multiples of these two banks. Ideally, banks have to consider business wise P-E ratio and multiply it with earnings of each portfolio to arrive at the value of equity Jayedev, (2000).

Jayedev, further reported that In terms of the variable costs model, financial institutions compete in areas such as price and service. In this case, a bigger volume of activity results in an increase in variable costs. On the contrary, the model based on sunk costs assumes that banks compete with fixed investments and sunk costs in order to penetrate a market. If competition is based on variable costs, the scale of banks is not decisive for their efficiency once a certain minimum scale has been reached. But under the model

based on sunk costs, scale can become decisive. Hence to explore investment banking activity (Based on sunk costs), large size banks would be required. To ensure the availability of financial services to all segments of the population, voluntary mergers conditional upon the disadvantaged segments being unaffected by the process and approval should be linked to specific plans offered by the acquirers to mitigate the extent of financial exclusion.

The bank merger phenomenon has been widely accepted as the way to achieve performance improvement, especially when merger activities focus on geography, economies of scale, and activity lines, DeLong, (2001), Houston *et al*, (2001). In addition, many argue that bank mergers could improve economies of scale and cost reduction when they share information, transaction system and monitoring costs van Rooij (1997). The economies of scale of merged banks could be achieved since they can reduce the average cost by expanding the volume of similar banking products.

Therefore, when the economies of scale argument hold, then the greater the benefits received by the merged banks, Jensen and Ruback (1983). Study on the effect of bank mergers on performance has been conducted in many countries with various findings. For example, Allen and Boobal-Batchelor (2005) studied the post-crisis bank mergers in Malaysia. The study found that the target banks tend to be less efficient than those acquiring banks. Furthermore, most efficiency gains were found due to an improvement in managerial efficiency. In contrast, Kwan (2004) based on US banking consolidation policy in 1997 raised issue of whether mergers contributed to the efficiency gains.

Findings from previous studies of bank mergers in Indonesia also show various results. For example, Samosir (2003) found that there were no performance differences between before and after the merger. In contrast, Soemonagoro (2006) found that a merged bank experienced a continuing performance improvement from 1999 to 2005. However, its loan-to deposit ratio was relatively low indicated that the bank failed to fulfill its function as an intermediary institution. Other study by Hadad *et al.* (2003) found that only privately-owned banks found as the most efficient banks. In addition, Putra (2003) revealed that on average the technical efficiency of 45 foreign exchange Indonesia banks were 71.26 percent and 74.37 percent on 2001 and 2002 respectively.

#### **2.3.4 Net Interbank and Capital Structure**

According to Rochet and Vives (2004), since individual interbank market participants are generally risk averse and have only asymmetric information, they may rationally overreact to any negative news about their counterparty and withdraw their assets as quickly as possible. Such a generalized liquidity crunch may push a solvent institution into illiquidity and bankruptcy.

Degryse and Nguyen (2007) are the first to empirically investigate the impact of interbank market structure on contagion risk. Assuming exogeneity of the market structure they find the latter to be one of the main drivers of contagion risk on the Belgian interbank market. Castiglionesi and Navarro (2008) however model how the interbank market structure evolves endogenously from first principles. In their model, two banks have to agree to establish a link (this is the notion of pairwise stability). The rationale of the model is that, when the probability of default is too high, the safe banks

do not want to be linked with the risky ones and accordingly sever their links, while the risky banks find it almost always convenient to be linked.

Freixas and Jorge (2007) and Allen *et al.* (2008) signal that banks should not be able to monitor their peers because interbank markets, like other credit markets, are characterized by moral hazard and asymmetric information. Likewise, Goodfriend (2002) and Martin and McAndrews (2007) claim that banks are not apt to monitor other banks, because the implicit guarantee supplied by central banks, which are expected to intervene in case of crisis, undermines banks' incentives to monitor their peers. On the other hand, Rochet and Tirole (1996) demonstrate that interbank exposures might generate incentives for lending banks to monitor borrowing banks, even if this disciplinary role is relatively ineffective because interbank exposures can be quickly abandoned owing to their typically short-term maturity.

King (2008) demonstrates that high-risk banks pay more than safe banks for interbank loans. Dinger and von Hagen (2009) show that in systems characterized by longer-term interbank exposures the monitoring role of lenders is more important.

Angelini *et al.* (2011) also analyse the Italian interbank market before and after crisis. Although their focus is different, as they study the determinants of the interbank interest rate spread, my findings are consistent with their main conclusion. They find that the widening interbank spread was not due to bank-specific factors but to increasing aggregate risk aversion;

Following Gale (2004), bank capital is considered as a buffer to shield deposits from banks' liquidity shocks and then it represents an additional (costly) source of liquidity insurance. Gale argues that bank capital also has a risk-sharing function. He presents a model of capital as a buffer stock, in which the optimal capital structure improves risk-sharing between shareholders and depositors. Similarly to Gale, we focus on the risk-sharing role of bank capital. However, the effect of the participation in interbank markets in determining bank capital is closely analyzed. The emphasis on the relationship between bank capital and participation in interbank market arises naturally given that, at least in principle, interbank markets reduce the scope for bank capital as a risk-sharing device. A two-region economy is modeled, in which each region is populated by risk-averse depositors and risk-neutral investors. While the former deposit their endowment in banks, the latter provide bank capital. Banks acting on behalf of depositors have two investment opportunities: a short-term liquid asset (storage technology) and a long-term illiquid asset.

Each region has uncertain liquidity needs characterized by a regional liquidity shock. The existence of an interbank deposit market *allows* banks in different regions to coinsure when regional liquidity shocks are negatively correlated. However, interbank markets are of little help when liquidity shocks are positively correlated. Therefore, some residual aggregate uncertainty remains. The presence of aggregate uncertainty gives a scope for the use of bank capital as a risk-sharing device. That is, some of the undiversifiable risk can be transferred (at a cost) to risk-neutral investors. In a world without aggregate uncertainty the interbank market would be sufficient to deal with idiosyncratic liquidity

shocks and there would be no need for bank capital. It follows that a reduction in aggregate uncertainty should imply a reduction in bank capital as well. This is indeed the case for certain parameters values but, surprisingly, it is not a general property of the model (Gale, 2004).

This is due to the fact that a reduction in aggregate uncertainty implies also a reallocation in the investment decisions of the banks. In particular, when aggregate uncertainty reduces banks have an incentive to reduce the investment in the liquid asset and, as in Castiglionesi *et al.* This can cause higher consumption volatility. Bank capital in this case is valuable since it helps in moderating such volatility. Given that higher aggregate uncertainty implies lower interbank market participation, the model predicts a negative relationship between interbank market participation and bank capital only insofar bank capital is increasing in aggregate uncertainty.

Furthermore, banks collect a capital buffer to transfer part of the aggregate uncertainty to the risk-neutral investors. In our model, this is achieved by paying a dividend which is contingent on aggregate liquidity needs. In particular, when aggregate liquidity needs are high throughout the economy, it is optimal to postpone dividend payments. Given that in this case the interbank market is unable to provide additional liquidity, at the same time that banks postpone dividends they also tend to have smaller positions vis-a-vis other banks. This mechanism should produce a positive relationship between dividend payments and participation in the interbank market, as measured for example by the magnitude of the interbank net position, which is possible to validate empirically.



The model also predicts a negative relationship between current and future dividends so that when interbank market participation is low, current dividends are also low but future dividends tend to be high. This means that there exists a negative relationship between interbank market participation and changes in dividend payments, that is, dividends tend to increase over time when interbank participation is low.

Finally, dividend payments also affect the value of bank capital. Namely, the payment of current dividends tends to reduce capital, both for an accounting reason and, within this framework, also because it signals lower dividends in the future. The postponement of a dividend instead signals higher future payouts to shareholders, and the value of bank capital should increase as a consequence. Since dividends are paid (postponed) when the participation in the interbank market is high (low), the model also delivers the testable prediction of a negative relationship between changes in bank capital and participation in the interbank market.

## 2.4 Conceptual frame work

### Independents Variables

### Dependents variable

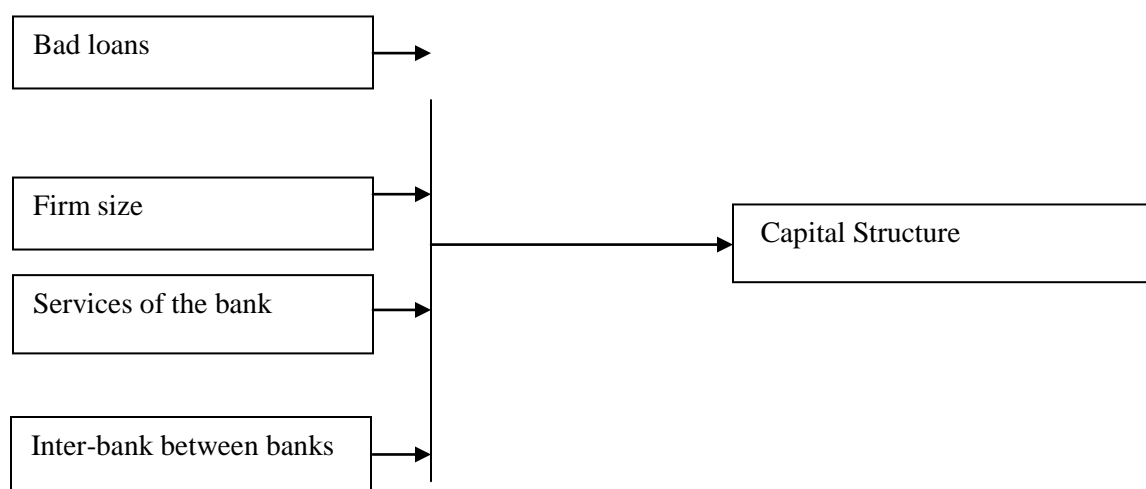

*Figure 2.1: Conceptual framework*

## **Explanation and Measurement of Variables**

### **Dependent variable**

Capital structure was measured by debt and equity valuation of the firm.

### **Independent variables**

Mergers were measured on bad loans, firm size, Services and interbank. Bad loans were measured by ratio of bad debts and total landings of the firm. Firm size was measured by log of total assets. Services was measured by the ratio of income from services to total gross income while interbank was measured by net interbank balance divided by total assets

## **CHAPTER THREE**

### **RESEARCH METHODOLOGY**

#### **3.0 Introduction**

This chapter describes the methods and procedures that were used to carry out the study. It presents the study design, target population, data collection instruments and procedures and data analysis techniques.

#### **3.1 Research Design**

This study adopted an explanatory research design. This was because the study was of a cause-effect relationship De Vaus, (2001). This design was the best for ascertaining the effects of mergers on the capital structure of the firm.

#### **3.2 Target Population**

The target population of this study was the published financial statements of the NIC bank, the years of the published ranged between 1995 – 2010, that is 4 years before the merger, and 12 years after merger. The study observed quarterly financial statements only, hence a total of 64 observations and thus the target population is chosen since it provided research information in respect to the study.

#### **3.3 Sampling Size and Procedure**

Census method was employed in the study for all published financial reports for NIC bank during the sixteen year period on quarterly basis.

### **3.4 Data Collection Method**

The study considered the secondary data collection method. This includes published annual financial reports for the pre and post-merger periods of NIC Bank ranging from years 1995 to 2010. To analyze the merger, the balance sheets of NIC Bank and AM Bank are involved throughout the whole period studied so as to consider them as a single bank from the beginning. A Proforma balance sheet is computed by consolidating the balance sheets of the merging banks involved throughout the period. This was to determine how mergers affected the firm's capital structure. The research avoided the years 1998 to 2004 being the transitional period. During the period there was a lot excitement and abnormal behavior in the market. Further information was obtained from internet based articles and reports mostly on the NIC Merger (Kenya annual list report, 2010).

### **3.5 Data Analysis**

The study used quantitative technique to analyze data of NIC bank before and after merger. Quantitative data was analyzed using descriptive and inferential statistics methods. Descriptive statistics was used to summarize and present the data of NIC bank before and after merger by the measures of central tendency and dispersion using statistical methods like the mean, median, mode, variance and standard deviation. Statistical tools such as frequency distribution tables and bar charts were used. Inferential statistics was used to analyze and evaluate data of NIC bank before and after merger using correlation and regression models

### 3.6 Model Specification

The data collected was analyzed using multi regression and correlation analysis. The significance of each independent variable was tested at a confidence level of 95%. The regression equation of the form below was applied. Linearity, multicollinearity and normality are the assumptions of the model which were tested in the study.

$$Y = \alpha + \beta_1 X_1 + \beta_2 X_2 + \beta_3 X_3 + \beta_4 X_4 + \varepsilon$$

Where,

Y = Capital structure of the firm measured by equity and debt valuation of the firm. This is the dependent variable.

$\alpha$  = constant.

$\beta_1 \dots \beta_4$  = the slope which represents the degree in which capital structure of the firm changes as the independent variable change by one unit variables.

$X_1$  = bad loans

$X_2$  = Firm size

$X_3$  = services

$X_4$  = Interbank

$\varepsilon$  = error term

### 3.7 Limitations of the Study

NIC Bank is a limited liability company and it is a member of the Nairobi Stock exchange. Its financial information pertaining to market share, its capital valuation, capital structure, tax regime, synergy and others is available. However there was limitation of using secondary data. There was less control over how the data was

collected and that there could be biases in the data used in this study. The researcher took sufficient steps to critically evaluate the validity and reliability of the information provided by ensuring that every report is properly authenticated.

In many cases secondary data is not presented in a form that exactly met the researcher's needs. Therefore, the researcher relied on secondary data that was presented and classified in a way that is similar to their needs. While using secondary research, caution was taken on information from the past so that out-of-date research reports many have little or no relevance to the current study. There was missing or inconsistency of data in the transitional period of the merger. In conclusion, the use of secondary research offers many significant advantages to the researcher.

### **3.8 Ethical Considerations**

The study ensured that ethical issues were highly observed as far as confidentiality and respect are concerned. Further the researcher assured the NIC bank that the data collected from the financial reports was used for the purposes of the study only.

## CHAPTER FOUR

### DATA ANALYSIS, PRESENTATION AND INTERPRETATION

#### 4.0 Introduction

This chapter entails analyses of data and estimate the model described in the previous chapter. Data was quantitative secondary data. Quantitative data was analyzed using descriptive statistics such as mean, mode, median and inferential statistics such as correlation and regression. Data is also presented using tables, graphs and charts.

#### 4.1 Descriptive Statistics

The following figures illustrate distribution of total asset, total equity, total lending, gross income, income from services, bad loan, and interbank assets before and after the merger of NIC bank.

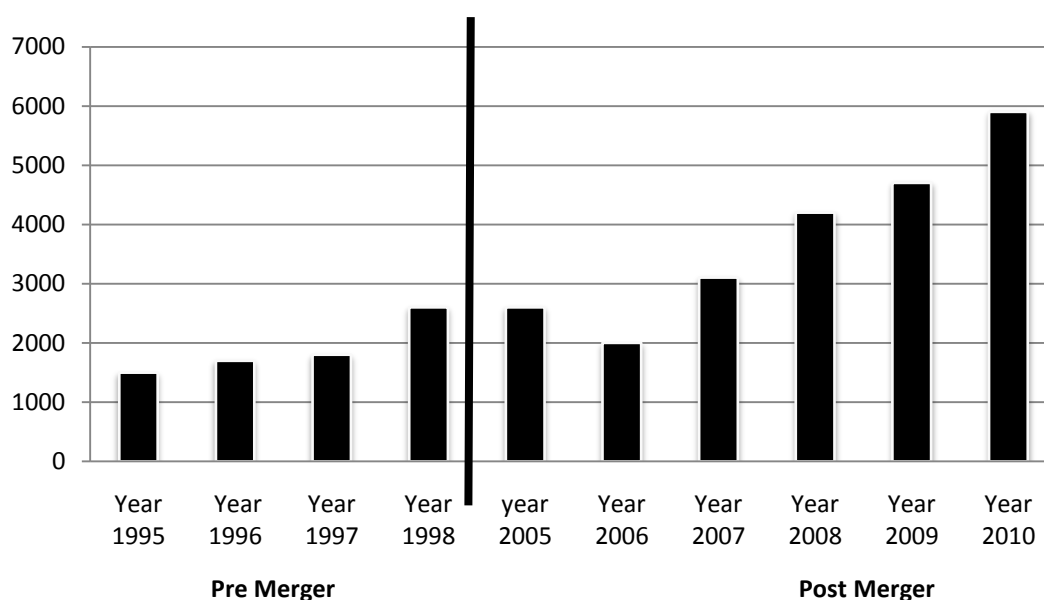

**Fig 4.1: Distribution of total asset**

Source: Research data (2012)

Fig 4.1 shows that during the advent of mergers, there is a marginal increase in the total assets for the merged entities as compared to marginal increase before the merger.

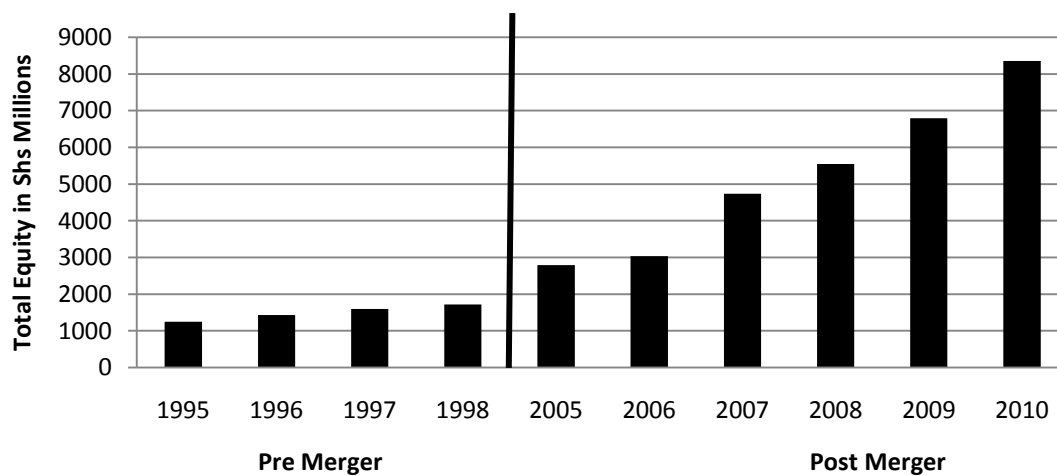

**Fig 4.2: Distribution of Total equity**

Source: Research data (2012)

Fig 4.2 shows that, there was a steady and exponential increase in the total equity when a comparison is made of the periods 1995 to 1998 and periods 1998 to 2010.

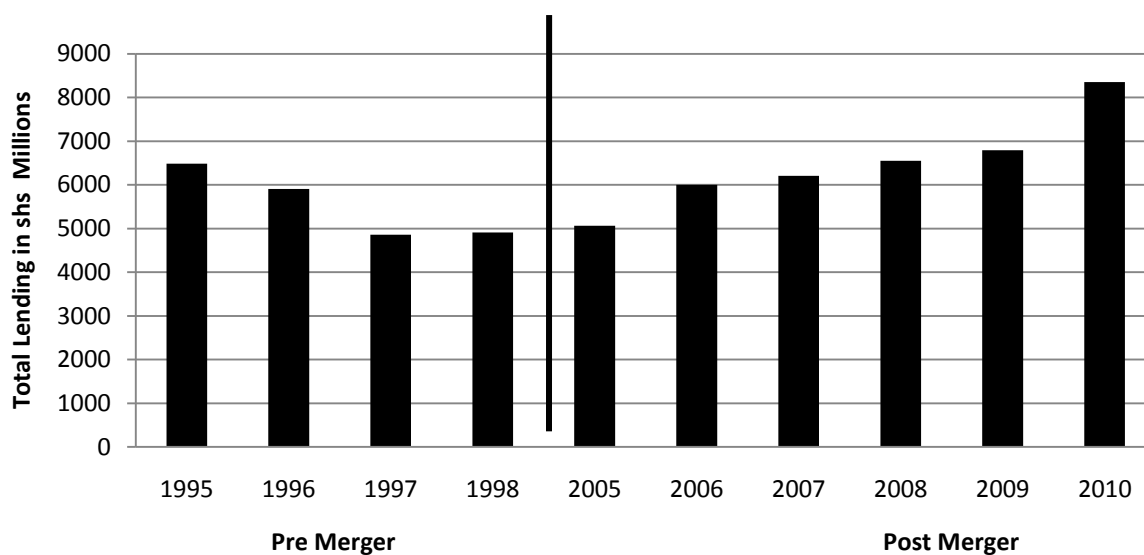
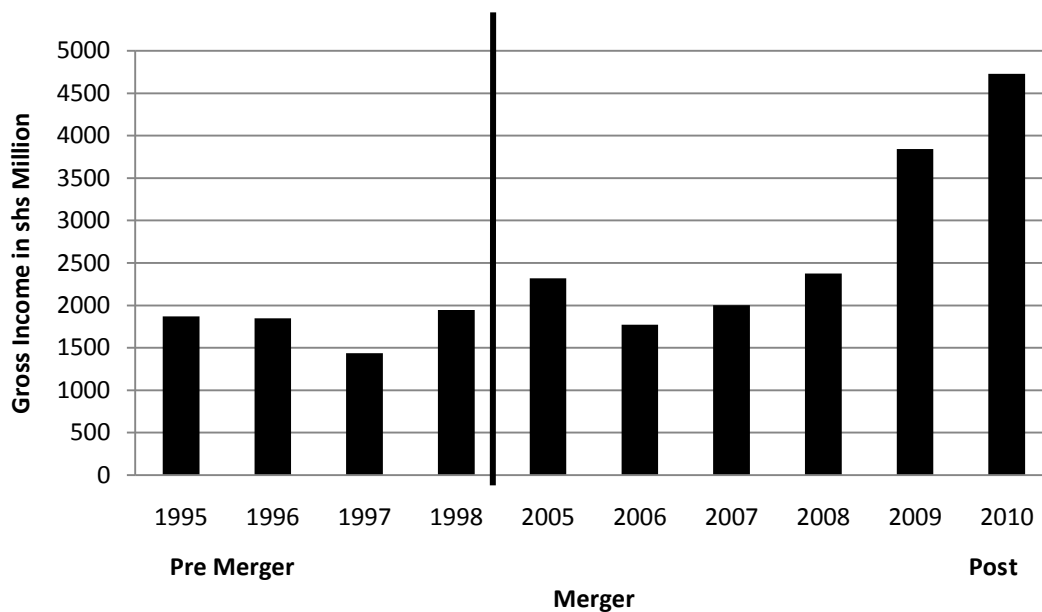

**Fig 4.3: Distrubution of Total lending**

Source: Research data (2012)



The lending decreased steadily between 1995 and 1997 but increased exponentially between 2005 and 2010. This might point to the reason that the merger happened, it might be due to the decreasing lending rates and after the merger, the decreasing trend is drastically reversed as shown by fig 4.3 above .



***Fig 4.4: Distribution of Gross income***

Source: (Research data, 2012)

The gross income graph above depicts a steady decline in the average gross income from 1995 to 1997 and a steady average increase between the year 2005 and 2010. This was explained by the fact that during mergers the gross income levels first declined and then increased due to the shifting trend in the labor available and the cost associated with mergers that demand total overhaul of the system hence the income.

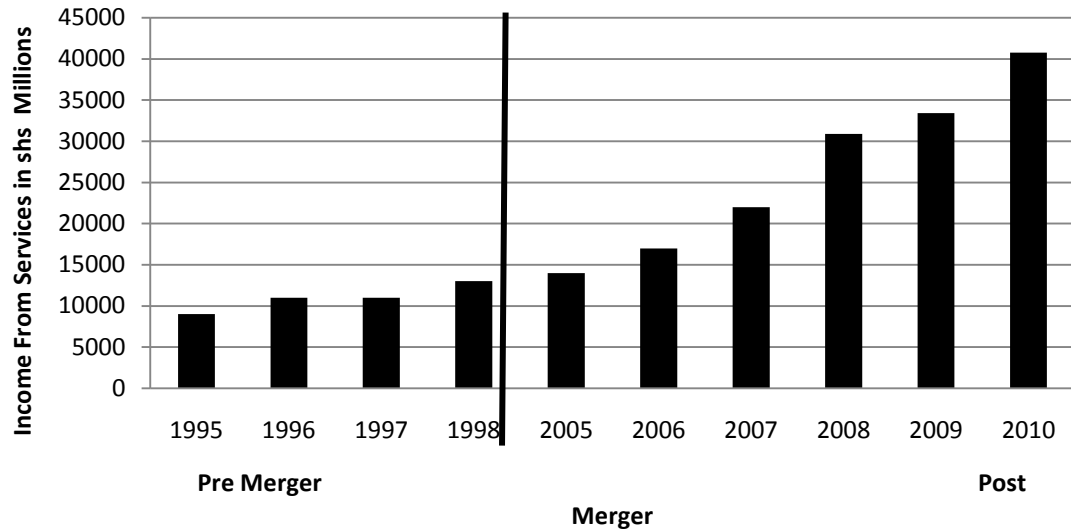

*Fig 4.5: Distribution of Income from Services*

Source: Research data (2012)

The table above shows that there was a slow but exponential increase in the income from services from 1995 to 1998 and then a sharp exponential increase from 2005 to 2010. This relates with Terry (2002) that Merged banks supply the same quantity of services that now contain better quality and thus incur higher cost, hence the discrepancy between the cost and the profit efficiencies.

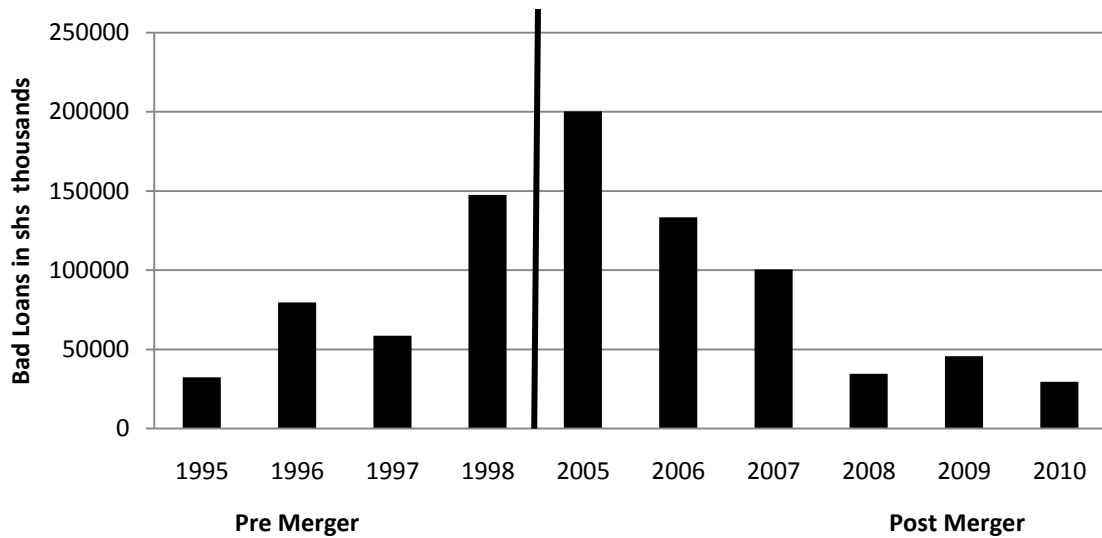

***Fig 4.6: Distribution of Bad Loan***

Source: Research data (2012)

The bad loans increased exponentially from 1995 to 1998 and reached their peak in 2005 thereafter, they decreased exponentially after the mergers and leveled out between 2008 and 2010 years. This is an effect of merging in that, the bad loans are either written off or due to the change in structures, the management of bad loans is dealt with to ensure that under the new dispensation, they are not too high.

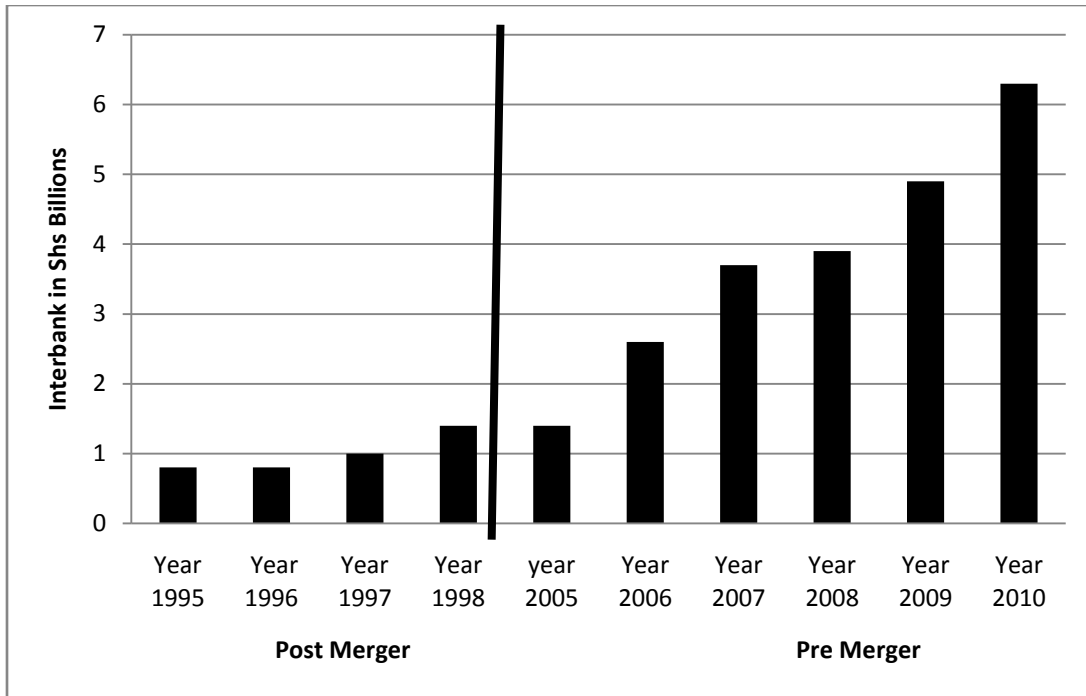

***Fig 4.7: Distribution of Interbank***

Source: Research data, (2012)

Interbank increased relatively exponentially from 1995 to 1998 and then there was a sharp exponential increase after the merger from 2005 to 2010. This implies that there was more trade in terms of interbank after the merger and this highlights another benefit of mergers.

**Table 4.1 Descriptive Statistics (Means Differences)**

Variable	Before Merger		After Merger		T test	P value
	Mean	Standard Deviation	Mean	Standard Deviation		
Total asset	15,912.45	2,384.45	37,872.33	14,430.05	1.64	0.001
Total equity	1,500,000	204,480	5,210,000	215,800.0	4.7	0.001
Total lending	5,540,000	793,347.4	6,500,000	108,800.0	15.32	0.991
Gross income	1,780,000	229,579.3	2,850,000	117,000.0	11.99	0.467
Income from services	1,100,000	163,300.0	2,630,000	103,600.0	2.44	0.248
Bad loan	7,950,000	492,900.0	9,200,000	702,800.0	13.72	0.046
Interbank	3,854,000	172,757.0	9,855,800	265,685.0	2.76	0.043

*Means in thousands*

Source: Research data (2012)

Results from Table 4.1 indicated a smaller total mean asset 15, 912.445 before the merger than after the merger where a higher total mean asset 37,872 was reported, this mean difference was significant as revealed by t test = 1.639 and P value of 0.01. This coincides with Focarelli *et al*, (2003) that mixed firm size industries are most likely to exhibit merger waves, because some firms have defensive as well as positioning merger motives. The mean of total equity before the merger was 1,500,000 while after the merger the total equity mean was 5,210,000. This implies that after the merge the bank recorded

a increase in the mean of total equity with T-test = 4.7, p-value = 0.001 < 0.05 ( $\alpha$ ). Hence there is significant mean difference between the total equity before and after the merger.

The analysis revealed that there exists no mean difference in total lending before and after the merger. Before the merger total lending mean was 5,540,000, while after the merger the mean was 6,500,000. Although there is difference among the mean this difference was not significant as shown by t test = 15.32 and p value of 0.991.

The study analysis reported that gross income mean before merger was 1,780,000 which was less than gross income mean after the merger of 2,850,000. This mean difference was found not significant as revealed by The T-test=11.99 and p-value = 0.467 >  $\alpha$  (0.05). Thus, there exists no mean difference in gross income before and after the merger.

As seen from table 4.1, the mean of income from services before the merger was 1,100,000 but after the merger, the mean increased to 2,630,000. This increase was however regarded as insignificant (the T-test = 2.44 and that p-value = 0.248 >  $\alpha$  (0.05).

More findings showed that there was mean significance difference of bad loans before the merger (mean = 7,950,000) and after merger (mean = 9,200,000) as evidence of the T-test = 13.72 indicated that, p-value = 0.0046 <  $\alpha$  (0.05).

Findings on interbank showed that the mean of interbank before merger was 3,854,000 whereas after the merger the interbank mean was 9,855,800. The t test = 2.76, and p value = 0.043 reported that the mean difference was significant.

**Table 4.2 Descriptive Statistics for Variables**

This study conducted descriptive statistics to describe the basic features of the data. Through this statistical tool the study was able to find out the variable ratios, their mean, standard deviation, minimum value and maximum value.

<b>Before Merger</b>					
	<b>Mean</b>	<b>Median</b>	<b>Std. Deviation</b>	<b>Maximum</b>	<b>Minimum</b>
Bad Loans	0.1353	0.7695	0.0947	0.98	0.02
Services	0.276	0.3195	0.20221	0.81	0.66
Interbank	0.061	0.0595	0.00997	0.05	0.01
Firm Size	15.9127	16.3345	2.38445	18.27	12.71
Capital structure	0.8255	0.7576	0.68466	0.99	0.74
<b>Transitional Period</b>					
Bad Loans	0.0097	0.0084	0.00464	0.02	0.01
Services	0	0	0	0	0
Interbank	0.0005	0.0005	0	0	0
Firm Size	6.7318	6.8482	0.24932	6.97	6.41
Capital Structure	1.63079	1.54572	0.86467	1.78	0.27
<b>After Merger</b>					
Bad Loans	0.8435	0.45	0.34082	0.53	0.16
Services	0.4645	0.151	0.40695	0.99	0.88
Interbank	0.1833	0.1025	0.1126	0.62	0.07
Firm Size	37.8723	36.95	14.43005	59.01	20.7
Capital Structure	1.81	1.2265	0.54190	1.88	1.01

Source: Research data (2012)

The study of analysis reported that the mean bad loan ratio was 0.1353 before the merger while after the merger the bad loan mean ratio was 0.8435. Nevertheless mean of bad

loan ratio in the transitional period was 0.0097 suggesting that bad loan was more employed before merger and reduced in transitional period and picked again in after transitional period.

In the transitional period firms income from services mean ratio was found to be 0.00 having a huge significance different from mean of pre- post merger. Before merger firm income from service loan was 0.276. while after the merger services of the NIC bank was 0.4645. Comparing the mean of firm size before the merger, transitional period and after the merger, the study findings revealed that transitional period had the lowest firm size mean (mean = 6.7318) this might be as result of high liquidity.

Interbank before merger was reported to have a mean score of 0.016, while after merger the mean increased up to 0.1833. In transitional period the mean of interbank was the lowest = 0.0005.

#### **4.2 Pre and Post Merger Correlation Analysis**

After performing the statistics the researcher investigated the correlation of bad loans, income from services, net interbank, firm size and capital structure before and after the merger of the NIC bank. The analysis was done by the measurement of the ratio of bad loans to total lending, ratio of total income from services to gross income, ratio of net interbank to total asset and the log of total assets in NIC bank. Capital structure was measured by the ratio of total debts to total equity.



**Table 4.3 Pre and Post Merger Correlation Analysis**

Before Merger					
	Bad Loans	Services	Interbank	Firm Size	Capital Structure
Bad Loans	1				
Services	0.451*	1			
Interbank	0.647	-0.038	1		
Firm Size	0.553*	0.843	0.298	1	
Capital Structure	0.107	0.527*	-0.185*	0.61*	1
Transitional Period					
Bad Loans	1				
Services	1	1			
Interbank	-0.149	-0.147	1		
Firm Size	0.386	0.387	0.737	1	
Capital Structure	0.528	0.527	-0.777	-0.261	1
After Merger					
Bad Loans	1				
Services	0.634	1			
Interbank	0.467	-0.124*	1		
Firm Size	0.881*	0.238	0.738	1	
Capital Structure	0.716*	0.706*	-0.643*	0.811*	1

\*\*Correlation is significant at the 0.01 level (2-Tailed).

\*Correlation is significant at the 0.05 level (2 – Tailed)

Source: Research data (2012)

The results from table 4.3 indicate that before merger there was no relationship between capital structure and bad loan. Pearson correlation value was 0.107 and the p value was 0.893 which is more than  $\alpha = 0.05$ . Nevertheless the study observed that after the merger, bad loan was significantly positively correlated to capital structure. Pearson correlation

was 0.716 and the p value was 0.009. This implies that before the merger bad loans had no associations with capital structure but after the merger bad loans would associate with capital structure positively.

Regarding income from services, the findings revealed that before merger there existed a significant positive correlation of 0.527 between income from services and capital structure and p value of 0.04 which is less than  $\alpha = 0.05$ . Hence the study concluded that there was a positive correlation between capital structure and income from services. However, after the merger the correlation between capital structure and income from services increased. Pearson correlation was 0.706 and a p value of  $0.004 < \alpha = 0.05$ .

Before the merger interbank indicated a weak significant negative relationship with capital structure (Pearson correlation = -0.185, p value =  $0.041 < \alpha = 0.05$ ). Further analysis after the merger reported a very strong negative significant relationship between capital structure and interbank ( $r = -0.643$ , p value = 0.048).

Firm size and capital structure had significant positive relationship (Pearson correlation = 0.61 and p value of  $0.03 < \alpha = 0.05$ ). Further analysis after the merger reported a very strong negative significant relationship between firm size and capital structure (Pearson correlation = 0.811, p value = 0.05). This contradicts Focarelli, Panetta, and Salleo (2003) suggestions that if a firm becomes very large and its manager's private benefits are high and may engage in an unprofitable defensive acquisition. In their study that there is a negative correlation between acquirer returns and acquirer size because large firms are

more likely to engage in defensive acquisitions than small firms. More specifically, their theory implies that large firms tend to make negative NPV acquisitions (leading to negative abnormal returns), medium size firms both positive and negative NPV acquisitions, and small firms positive NPV acquisitions. In such industries, the only acquisitions that large firms undertake (with the exception of the largest firm) are of defensive nature. They occur if private benefits are high (if private benefits are sufficiently low, they do not make any acquisitions).

Further findings shows that during transitional period bad loans, services, interbank and firm size had no relationship with capital structure.

### 4.3 Regression Analysis of Bad Loan, Services, Interbank and Firm Size against Capital Structure

**Table 4.4 Regression Analysis**

<b>Before Merger</b>					
<b>Standardized Coefficients</b>					
	<b>Beta</b>	<b>Std. Error</b>	<b>T- Test</b>	<b>P Value</b>	<b>VIF</b>
(Constant)	1.143	9.515	0.12	0.912	
Bad Loans	0.079	0.205	0.091	0.934	2.001
Services	0.125	2.027	0.093	0.031	0.911
Interbank	-0.306	128.14	-0.035	0.003	2.422
Firm Size	0.316	1.207	0.01	0.002	1.301
$R^2=0.743$					
$F=22.08$					
$P Value=0.007$					
<b>Transitional Period</b>					
(Constant)	10245.5	5445.296	1.882	0.201	
Bad Loans	0.169	822.385	0.384	0.738	3.579
Interbank	-1.118	1120000	-1.858	0.204	2.241
Firm Size	0.498	22.383	0.771	0.521	2.007
$R^2=0.828$					
$F=3.219$					
$P Value=0.246$					
<b>After Merger</b>					
(Constant)	22.143	51.602	2.473	0.012	
Bad Loans	0.894	0.726	2.334	0.004	0.988
Services	0.641	1.947	2.709	0.000	1.681
Interbank	-0.511	15.081	0.167	0.003	0.561
Firm Size	0.940	0.668	2.672	0.002	1.112
$R^2=0.847$					
$F = 2.547$					
$P Value=0.01$					

Dependent: Capital structure

Source: Research data (2012)

The regression results from table 4.3 shows that regression before merger had a coefficient of determination ( $R^2$ ) of 0.743 and F test (ANOVA) of 22.08 with a p value of 0.007. This means that bad loans, services, interbank and Firm size explain 74% percent of the variations in capital structure of NIC bank. The F-value of 22.08 with a p value of 0.007 at 5% significance level is significant indicating that the joint contribution of the independent variables (bad loan, services, interbank and Firm size) was significant in predicting the dependent variable (capital structure). After the merger, regression analysis on the same variables indicated an increase in  $R^2$  by 10% implying that after the merger interbank, service, bad loan and firm size explain 84% of the variations in the capital structure as compared to 74% before the merger. This indicates that independent variables have more strength in predicting the capital structure after the merger as compared to before the merger.

Harford (2005) tries to identify the reason of merger waves. He finds that one very important reason for the merger clustering in time is sufficient overall capital liquidity, which implies lower financial constraint or transaction costs. Combining both findings, we expect that firm's capital structure should play an important role in the merger activities. Specifically, we are interested in the interaction between Merger and firm's capital structure.

#### **4.3.1 Effect of bad loan on capital structure before and after merger**

Findings in table 4.5 showed that Bad loan had  $\beta_1 = 0.079$ . However, the p value was 0.934 which is more than  $\alpha = 0.05$  indicating that the bad loan are not statistically

significant in determining the capital structure in NIC bank before merger. Surprisingly after the merger the results of regression analysis indicated otherwise, one unit increase of bad loan increases capital structure with 0.894 units (coefficient estimate = 0.894) with a p value 0.004. This results entails that bad loan increase will reduce return on earning hence compelling the firm to borrow thus increasing the total debts.

The costs associated with issuing debt are the costs of financial distress (Modigliani and Miller, (1963) and the firm costs is triggered by conflicts between shareholders and debtors which was indicated by Ozkan (2001), that costs of financial distress will arise when a firm uses many unnecessary debt and is powerless to meet the interest and principal payments. The trade-off theory entails a target adjustment model. In the model, firms contain a target debt ratio in which they slowly adjust. The debt is adjusted by comparing the ratio of debt in the preceding period with the predetermined target debt ratio.

Rapidly growing firms (and industries) have a surfeit of positive net present value projects while slow-growth firms may have an excess of cash. Jensen and Meckling (1976) suggest that a particular capital structure can result from using debt as a monitoring and controlling device for managers. Further developing the "free cash flow" argument, Jensen (1986) points out that slow growth firms will have large amounts of excess cash that managers may decide to use for the Determination of Optimal Capital Structure personal perquisites and other non-positive net present value projects

### **4.3.2 Effect of income from services on capital structure before and after the merger**

Before the merger service indicated a positive relationship with capital structure with a t test value of 0.093. From the results in table 4.5 the coefficient of estimate ( $\beta_2$ ) value for services was of = 0.125 indicates that increase of service with one unit yields 0.125 units in debt-equity ratio (capital structure), this increase was significant as shown by p value of 0.031 which is less than 0.5 confidence interval hence allowing to reject null hypothesis that  $\beta_2 = 0$ . This implies that before merger increase of services (while withholding gross income constant) offered by NIC bank would increase capital structure. After merger influence of services was very strong than before merger as evident of coefficient estimate = 0.641 and P value = 0.000 <  $\alpha = 0.05$  (the influence is significant). This contradicts Samosir (2003) found that there were no performance differences between before and after the merger. But it relates with Van Rooij (1997) who argued that bank mergers could improve economies of scale and cost reduction when they share information, transaction system and monitoring costs. The economies of scale of merged banks could be achieved since they can reduce the average cost by expanding the volume of similar banking products.

### **4.3.3 Effect of interbank on capital structure before and after merger**

Coefficient estimate for interbank before merger was -0.306 with p value of 0.003 <  $\alpha = 0.05$ , suggesting there was significant interbank influence on capital structure, one unit increase in interbank reduce capital structure with 0.306. However, after merger coefficient estimate increased up to -0.511 with a p value 0.003 implying that there was higher significant influence of interbank on capital structure after merger than before

merger. Gale, 2004 closely analyze the effect of the participation in interbank markets in determining bank capital. The emphasis on the relationship between bank capital and participation in interbank market arises naturally given that, at least in principle, interbank markets reduce the scope for bank capital as a risk-sharing device

#### **4.3.4 Effect of firm size on capital structure before and after the merger**

Effect of firm size on capital structure was reported to be strong after the merger. Before the merger firm size had coefficient estimate = 0.316 and P value = 0.002 <  $\alpha$  = 0.05 and that the coefficient was significant. But after the merger the coefficient estimate changed to 0.940 with a p value of value of 0.002 <  $\alpha$  = 0.05. This implies that increase of total asset with one unit yields 0.940 units to capital structure. This increase was significant as shown by p value of 0.002. Finally in the transitional period bad loan, services, interbank and firm size had no influence in the capitals structure. According to Focarelli, Panetta, and Salleo (2003) the effect of relative size of target and acquirer depends on the size of the acquirer. It shows that for medium sized firms, the ratio of target to acquirer size is negatively correlated with acquirer returns. This arises because medium sized firms acquire relatively large firms for defensive purposes if private benefits are high but relatively small firms in positioning mergers if private benefits are low. In contrast, for small acquirers, we conjecture that the ratio of target to acquirer size and the acquirer's abnormal returns are positively correlated.



## CHAPTER FIVE

### SUMMARY OF FINDINGS, CONCLUSION AND RECOMMENDATION

#### 5.0 Introduction

This chapter summarizes the study and makes conclusion and recommendations based on the results of the study. The policy recommendations from the findings and areas for further research are also presented. The researcher recommended to the bank management on strategic plans and financial evaluations to improve on merger effects of capital structure.

#### 5.1 Summary of Findings

The regression analysis showed that before merger, bad loan reported by NIC bank had no significant effect on capital structure. However after the merger bad loan had significant effect on capital structure ( $\beta_1= 0.894$ ).

According to Goldstein and Turner (1996) 'the accumulation of non-performing loans is generally attributable to a number of factors, including economic downturns and macroeconomic volatility, terms of trade deterioration, high interest rate, excessive reliance on overly high-priced inter-bank borrowings, insider lending and moral hazard'. Some writers also hold the view that bad loans can be caused by problem accounts. Rouse (1989) indicated in his work that problem loans can emanate from overdrawn account where there is no overdraft limit, overdraft taken on an account which has not been actively operated for some time and overdraft taken in excess of reasonable

operational limits. He also identified lack of good skills and judgment on the part of the lender is a possible cause of bad loans.

Bloem and Gorter (2001) indicated that non-performing loans may rise considerably due to less predictable incidents such as the cost of petroleum products, prices of key export products, foreign exchange rates or interest rates change abruptly. They also stated that deficient bank management, poor supervision, overoptimistic assessments of creditworthiness during economic booms, and moral hazard that result from generous government guarantees are some of the factors that lead to bad loans.

In the case of income from services offered by the NIC bank, the findings indicated that before of merger, there existed a relationship between services and capital structure. However after the merger, services were reported to positively impact on capital structure ( $\beta_2= 0.641$ ).

The regression results analyzed predicted a negative relationship between interbank and capital structure before the merger. Surprisingly, the results reported that after the merger, interbank had stronger effect on capital structure ( $\beta_3= -0.511$ ). After the merger interbank mean increased with huge significant difference.

In the case of firm size, correlation analysis indicated a very strong significant positive relationship between firm size and capital structure after the merger. This relationship was emphasized on regression analysis where the results reported a one unit increase in

total asset yielding 0.940 units in capital structure. Empirical results on total asset recorded a major significant of total asset mean before and after the merger. Increase of total asset was observed after the major merger. This result coincides with the New York Times reports that mixed firm size industries are most likely to exhibit merger waves, because some firms have defensive as well as positioning merger motives. Which motive matters depends on their managers' interest in maximizing firm value. While the additional acquisitions may not be undertaken by medium-size firms, those firms tend to make the most acquisitions in industries with economies of scale, firm size becomes the driving force for merger dynamics. Often, this leads to profitable acquisitions. However, if a firm becomes very large and its manager's private benefits are high, it may engage in an unprofitable defensive acquisition.

Other results from the findings reveals that it is likely those results might relate with New York Times report, 1994 that the effect of relative size of target and acquirer depends on the size of the acquirer. It shows that for medium sized firms, the ratio of target to acquirer size is negatively correlated with acquirer returns. This arises because medium sized firms acquire relatively large firms for defensive purposes if private benefits are high but relatively small firms in positioning mergers if private benefits are low.

## **5.2 Conclusion**

To analyze mergers, the researcher consolidates the balance sheets of the banks involved throughout the whole period studied. The study objectives were to find out the effect of NIC bank merger on its capital structure. The researcher subdivided these into effects of

bad loan, services, interbank and firm size of NIC bank merger on its capital structure. Based on the study findings merger caused firm size, bad loans and income from bank services to behave positively toward capital structure. Although firms size and income from services positively affected capital structure, after merger the effect was stronger than before merger. This confirms increase in firm size and income from services creates more channels for funds, thus reducing the rate of borrowing and hence total debts. Nevertheless, the study concurs that interbank reduces the capital structure ratio after merger. This implies that borrowing between merging banks decreases debts in capital structure.

### **5.3 Recommendations**

#### **5.3.1 Policy recommendations**

The researchers sought to address the reality of continued merger activity in the banking industry. The management of the Banks should be aware that mergers are increasingly faced with intensive global competition. They should be aware of the importance of mergers as a strategy in providing them with a competitive advantage in a free market system. The key to competing in the international market place is to simultaneously improve both quality and productive services on continual basis. In today's competitive and changing business world, mergers have brought changes in capital structure as well financial management effectiveness and efficiency. Banks should now be more concerned about the effects of capital structure as results of merger because they have now more ways of improving merger than before since researchers have come with a wide variety of merger practices literature .

### **5.3.2 Recommendations for Further Study**

The study found out that there has been a steady increase in total assets, services and interbank after the merger. The study recommends the following areas for scholars with interests in this area; Effects of merger on total asset, effects of merger on services, the role of the senior management in the provision of effective merger and factors affecting mergers and acquisitions.

## REFERENCES

- Afolabi J.A. (2004). Implications of the Consolidation of Banks for the Nigerian Banking System. Paper presented at the NDIC organized Workshop for FICAN Enugu.
- Allen D. and Boobal-Batchelo, V, (2005). The Role of Post-Crisis Bank Mergers in Enhancing Efficiency Gains and Benefits to the Public in the Context of A Developing Economy: Evidence from Malaysia”, Conference Proceeding Modeling and Simulation Society of Australia and New Zealand.
- Allen, F., and D. Gale, (2000), “Bubbles and Crises,” *The Economic Journal*, 110 (Jan): pp.
- Altman, E. (1968), Financial Ratios, Discriminate Analysis and the Prediction of Corporate Bankruptcy, *Journal of Finance*, 23,589-609.
- Ambrose, Brent W., & William L. Megginson (1992) “The Role of Asset Structure, Ownership Structure and Takeover Defenses in Determining Acquisition Likelihood,” *27 J. of Financial & Quantitative Analysis* 575.
- Andrade, Gregory, Mark Mitchell, and Erik Stafford, (2001), New Evidence and perspectives on mergers, *Journal of Economic Perspectives* 15, 103-120.
- Asquith, P. and E. Kim, (1982) “The Impact of Merger Bid on the Participating Firm’s Security Holders”, *The Journal of Finance*, vol.37, No.5, December 1982, 99. 1209-1228.
- Asquith, P. (1983), Merger Bids, Uncertainty, and Stockholder Returns, *Journal of Financial*.
- Banerjee, Ajeyo, and James Owers (1992), “Wealth Reduction in White Knight Bids,” *Financial*.
- Baxter, N. (1967) Leverage, Risk of Ruin and the Cost of Capital," *Journal of Finance* 22, September, pp.3956-403.
- Berger, A.N., Demsetz, R.S., Strahan, P.E. (1999). The Consolidation of the Financial Services Industry: Causes, Consequences, and Implications for the Future. *Journal of Banking and Finance* 23, 135–194.

- Bernstein, A, and John J. (2000). *Analysis of Financial Statements*. McGraw-Hill.
- Bloem, Adriaan and Cornelis N. Gorter (2001), "The Treatment of Nonperforming Loans in Macroeconomic Statistics" Working Paper No. 01/209, International Monetary Fund.
- Boating, P. (2004). Keynote Address: Bank governance and public interest. Global corporate governance forum, World Bank, London.
- Bon-Horim, M., S. Hochman and O. Palmon, (1987) "The Impact of the 1986 Tax Reform Act on Financial Policy," *Financial Management* 16, Autumn, pp. 29-35.
- Boquist, J.A., and W.T. Moore, (1984) "Inter-Industry Leverage Differences and the DeAngelo-Masulis Tax Shield Hypothesis," *Financial Management*, Spring, pp. 5-9.
- Bowen D, Ostroff C. (2004). Understanding HRM-firm Performance Linkages: The role of the "strength" of the HRM system. *Academy of Management Review*, 29, 203–221.
- Bradley, M., A. Desai and E. Kim, (1988), Synergistic Gains from Corporate Acquisitions.
- Bradley, M., G. Jarrell, and E. Kim, (1984), On the Existence of an Optimal Capital Structure: Theory and Evidence, *Journal of Finance*, 39, 857-878.
- Bradley, Michael, Anand Desai and E. Han Kim, (1983), the rationale behind interfirm tender offers. *Journal of Financial Economics* 11 (April): 183—206.
- Bruner, R. (2002), 'Does M&A pay? A survey of evidence for the decision-maker', *Journal of Applied Finance*, Vol. 12, pp. 48–68.
- Byrd, John, and Kent Hickman (1992), "Do Outside Directors Monitor Managers? Evidence.
- Cartwright, Susan; Schoenberg, Richard (2006). "Thirty Years of Mergers and Acquisitions Research: Recent Advances and Future working paper.

- Cuesta, R. A. and L. Orea (2002). Mergers and Technical Efficiency in Spanish Savings Banks: A stochastic distance function approach. *Journal of Banking and Finance* 26, 2231–2247.
- DeAngelo H. and R. Masulis (1980), Optimal Capital Structure under Corporate and Personal Taxation, *Journal of Financial Economics*, 8, 3-29.
- DeAngelo, H. and R. W. Masulis. (1980). “Optimal Capital Structure under Corporate and Personal Taxation,” *Journal of Financial Economics*, Volume 8(1), 3-29.
- Degryse, H., and G. Nguyen. (2007). “Interbank Exposures: An Empirical Examination of Contagion Risk in the Belgian Banking System.” *International Journal of Central Banking* 3 (2): 132–71.
- DeLong, G., DeYoung, R., (2007). Learning by Observing: Information Spillovers in the Execution and Valuation of Commercial Bank M&As. *Journal of Finance* 62, 181-216.
- DePamphilis, Donald (2008). *Mergers, Acquisitions, and Other Restructuring Activities*. New York: Elsevier, Academic Press. Pp. 740.
- Dinger, V. Von Hagen, J. (2009). Does interbank borrowings reduce bank risk? *Journal of Money, Credit and Banking* 41, 491-506.
- Eckbo, B. E., Giammarino, R. M., & Heinkel, R. L. (1990). Asymmetric information and the medium of exchange in takeovers: Theory and tests. *Review of Financial Studies*, 3: 651-675.
- Faccio, M. and R. W. Masulis. (2005). “The Choice of Payment Method in European Mergers and Acquisitions”, *Journal of Finance*, LX, (3), (June), pp. 1345-1388.
- Fishman, M., (1989), Preemptive Bidding and the Role of the Medium of Exchange in Acquisitions, *Journal of Finance*, 44, 41-87.
- Fishman, Michael J., (1989), Preemptive bidding and the role of the medium of exchange in acquisitions, *Journal of Finance* 44, 41-57.
- Focarelli, D., F. Panetta, and C. Salleo (2002). Why do Banks Merge? *Journal of Money, Credit and Banking* 34, 1047–1066.



- Focarelli, D., Panetta, F., (2003). Are mergers beneficial to consumers? Evidence from the market for bank deposits. *American Economic Review* 93, 1152-1172.
- Focarelli, D., Panetta, F., Carmelo, S., (2002). Why do banks merge?. *Journal of Money Credit and Banking* 34, 1047-66. From Tender Offer Bids,” *Journal of Financial Economics* 32 (2): 195-221.
- Fofack, Hippolyte L., (2005), “Nonperforming Loans in Sub-Saharan Africa: Causal Analysis and Macroeconomic Implications,” Policy Research Working Paper No. 3769 (Washington: World Bank).
- Gabriel, G. and S. Itzhak, (1990) Mergers and Acquisitions in the US Banking Industry – Evidence from the Capital Market, North-Holland.
- Goodfriend, M. (2002). *Monetary Policy in the New Neoclassical Synthesis: A Primer*, Federal.
- Hadad, Muliaman D., Santoso, Wimboh, Ilyas, Dhaniel & Mardanugraha, Eugenia, (2003), Analisis Efisiensi Industri Perbankan Indonesia”, Working Paper, Bank Indonesia.
- Hamada, R. (1972) m'The effect of the firm's capital structure on the systematic risk of common stocks'. *Journal of Finance*, May, pp. 435-452.
- Hansen, R. (1987). A theory for the choice of exchange medium in mergers and acquisitions. *Journal of Business* 60, 75-95.
- Harford, Jarrad, (2005), What Drives Merger Waves, *Journal of Financial Economics*.
- Harris, Milton, and Artur Raviv, (1991), The theory of capital structure, *Journal of Finance* 46.
- Hasbrouck, Joel. (1985). “The Characteristics of Takeover Targets.” *Journal of Banking and Finance* 9 (September): 351-62.
- Hempel, G., Coleman, A., and Smon, D. (1986), *Bank management text and cases*, Wiley, New York.
- Heracleous, L. and Murray, J., (2001). The Urge to Merge in Pharmaceutical Industry. *European management journal*.19(4):430-437.

- Hennessy, Hege, and, Ulrich (2010), Acquisition values and optimal financial (in) flexibility, *Review of Financial Studies* 23, 2865–2899.
- Houston, J.F, James, C.M., and Ryngaert, M.D. (2001). “Where do Merger Gains Come from? Bank merger from the perspective of the insiders and outsiders.”
- Ivashina, Victoria, Vinay Nair, Anthony Saunders, Nadia Massoud, and Roger Stover (2009). “Bank Debt and Corporate Governance.” *Review of Financial Studies* 22(1): 41-77 elly,
- Jalilvand, Abolhassan, and Robert S. Harris, (1984), Corporate behavior in adjusting to capital structure and dividend targets: An econometric study, *Journal of Finance* 39, 127–145.
- Jennings, Robert, and Michael Mazzeo (1991), “Stock Price Movements Around Acquisition.
- Jensen, M. (1986). Agency costs of free cash flow, corporate finance, and takeovers. *American Economic Review* 76, 323-329.
- Jensen, M., and W. Meckling. (1976). Theory of the firm: Managerial behavior, agency costs and ownership structure. *Journal of Financial Economics* 3, 305-360.
- Jensen, M.C. and R.S Ruback (1983). “The Market for Corporate Control: The Scientific
- John and Colin Cook (2001). “Synergies: A Business Guide, KPMG.
- Kester, W. Carl, 1986, Capital and ownership structure: A comparison of United States and Japanese manufacturing companies, *Financial Management* 15, 5–16.
- Kishan R. P. and Opiela T. P. (2000), “Bank Size, Bank Capital and the Bank Lending Channel”, *Journal of Money, Credit and Banking*, Vol. 32, No. 1, pp. 121-41.
- Koetter, M. (2005). Evaluating the German Bank Merger wave, *Deutsche Bundesbank. Discussion Paper Series* 2, 12/(2005).
- Koetter, M., J. W. B. Bos, F. Heid, C. J. Kool, J. W. Kolari, and D. Porath (2007). Accounting for Distress in Bank Mergers. *Journal of Banking and Finance* 10, 3200–3217.

- Kyereboah-Coleman, A. (2007), "The impact of capital structure on the performance of microfinance institutions", *Journal of Risk Finance*, Vol. 8 pp.56-71.
- Houston, J.F. and Ryngaert, (1994) Large Bank Mergers." *Journal of Banking and Finance* 18:, M.D.. "The Overall Gains from 1155–1176.Ivashina.
- Leland, Hayne E., (2007), Financial synergies and the optimal scope of the firm: Implications for mergers, spinoffs, and structured finance, *Journal of Finance* 62, 765–807.
- Lewellen, Wilbur G, (1971), A pure financial rationale for the conglomerate merger, *Journal of Finance* 26, 521–37.
- Lev, B. (1974) 'On the association between operating leverage and risk', *Journal of Financial and Quantitative Analysis*, September 1974, pp. 627-641.
- Long, M.S., Malitz, E.B., (1985). Investment patterns and Pnancial leverage. In: Freidman, B. (Ed.), *Corporate Capital Structures in the United States*. University of Chicago Press, Chicago, IL.
- Mandalker, G. (1974) "Risk and Return: The Case of Merging Firms". *Journal of Financial Economics* 1, Dec, pp. 303-336.
- Marsh, P., (1982). The choice between equity and debt: an empirical study. *Journal of Finance* 37, 121Ð144.
- Masulis, R.W., (1980). The effects of capital structure change on security prices: a study of exchange offers. *Journal of Financial Economics* 8, 139Ð177.
- Margrabe, William, (1978), the value of an option to exchange one asset for another, *Journal of Finance* 33, 177–86.
- Mergerstat Review (2000), Mergerstat Corp., Santa Monica, CA.Merger Premiums," *The Journal of Industrial Economics*, 41, pp. 91-102.
- Miller, M.H. (1977). "Debt and Taxes," *Journal of Finance*, Volume 32(2), 261-75.
- Modigliani, F. and M. Miller, (1958). The cost of capital, corporation finance and the theory of investment, *American Economic Review* 48, 261-297.

- Modigliani, F., and Miller, M. H., (1963), Taxes and the cost of capital: a correction. *American Economic Review* 53 (June).
- Morellec, Erwan, and Alexei Zhdanov, (2008), Financing and takeovers, *Journal of Financial Economics* 87, 556–581.
- Morck, R., Shleifer, A., Vishny, R.W., (1990). Do managerial objectives drive bad acquisitions? *Journal of Finance* 45, 31–48.
- Myers, S. C. (1984), The Capital Structure Puzzle, *Journal of Finance* ,39,575-592.
- Myers, S. C. and Majluf, N. (1984), Corporate Financing and Investment Decisions when Firms have Information that Investors do not have. *Journal of Financial Economics*, 13, 187-221.
- Holmstrom, Bengt, Kaplan, and Steven N, (2001) “Corporate Governance and Merger Activity in the United States: Making Sense of the 1980s and 1990s”. *Journal of Economic Perspectives*, 15,121–44.
- Ozkan, A., (2001). Determinants of Capital Structure and Adjustment to Long Run Target:
- Palepu, Krishna G. (1986) “Predicting Takeover Targets: A Methodological and Empirical Analysis,” 8 *J. of Accounting & Economics* 3.
- Palepu, Krishna. (1986). Predicting takeover targets: A methodological and empirical analysis. *Journal of Accounting and Economics* 8:1.
- Palia, D. (1993), “The Managerial, Regulatory, and Financial Determinants of Bank
- Pandey, I. M. (2005), *Financial Management*, 9th Edition, New Delhi: Vikas Publishing House PVT Ltd.
- Rhoades, S.A, (1998). The Efficiency Effects of Bank Mergers: An Overview of Case Studies of Nine Mergers. *Journal of Banking and Finance* 22, 273-91.
- Richard A and Stewart C M. (2008), *Principles of Corporate Finance*. Book Shaver, J. Myles. (2006). “A Paradox of Synergy: Contagion and Capacity Effects in Mergers and Acquisitions”. *Academy of Management Review*, 31(4): 962-976.

- Schwartz, E. and Aronson, J.R. (1967), "Some Surrogate Evidence in Support of the Concept of Optimal Financial Structure," *Journal of Finance* 22, March 7, pp. 10-18. [23].
- Scott, D.F. and Martin, J.D. (1975)"Industry Influence on Financial Structure," *Financial Management*, Spring, , pp. 67-73.
- Stulz, R. (1988). "Managerial Control of Voting Rights: Financial Policies and the Market for Corporate Control", *Journal of Financial Economics*, 20, pp. 25-54.
- Victoria, Vinay Nair, Anthony Saunders, Nadia Massoud, and Roger Stover, (2009). "Bank Debt and Corporate Governance." *Review of Financial Studies* 22(1): 41-77.
- Voulgaris, F., Asteriou, D., Agiomirgianakis, G. (2004), Size And Determinants Of Capital Structure In The Greek Manufacturing Sector. *International Review of Applied Economics*, 18(2): 247–262.
- Samosir, A P (2003), 'Analisis Kinerja Bank Mandiri Setelah Merger dan Sebagai Bank Rekapitalisasi', *Kajian Ekonomi dan Keuangan*, vol. 7:1, pp. 1-38.

## APPENDIX I: DOCUMENTARY ANALYSIS GUIDE

This documentary analysis sheet was used to guide the researcher while analyzing the NIC bank financial statements.

YEAR	Quarterly	Bad loan	Income from services	Size of a firm	Net Interbank balance	Gross income	Total assets	Total lending
1995	1st							
	2st							
	3st							
	4st							
1996	1st							
	2st							
	3st							
	4st							
1997	1st							
	2st							
	3st							
	4st							
1998	1st							
	2st							
	3st							
	4st							
1999	1st							
	2st							
	3st							
	4st							
2000	1st							
	2st							
	3st							
	4st							
2001	1st							
	2st							
	3st							
	4st							
2002	1st							
	2st							
	3st							
	4st							
2003	1st							
	2st							

	3st							
	4st							
2004	1st							
	2st							
	3st							
	4st							
2005	1st							
	2st							
	3st							
	4st							
2006	1st							
	2st							
	3st							
	4st							
2007	1st							
	2st							
	3st							
	4st							
2008	1st							
	2st							
	3st							
	4st							
2009	1st							
	2st							
	3st							
	4st							
2010	1st							
	2st							
	3st							
	4st							