

## Investigating the Use of Circle in Gear Cutting as a Substitute to Involute Profile

<sup>1</sup>A.D. Kibet, <sup>2</sup>A.M. Muumbo, <sup>2</sup>R.J. Kiprono and <sup>2</sup>S.K. Kimutai

<sup>1</sup>Department of Mechanical and Production Engineering, Main campus, Moi University, P.O Box 3900, Eldoret, Kenya

<sup>2</sup> Department of Mechanical and Production, Main campus, Moi University, P.O Box 3900, Eldoret, Kenya

**Abstract:** Gears are used in various machines and industries for transportation and transmission of power. Other uses are in consumer electronics and many machines used in homes like the washing machines, electric drills and kitchen appliances. Gears come in different sizes ranging from a module of 0.5 to 100 mm. Currently there is a problem of accurately machining gears. This is due to inaccurate positioning of the blank and cutter. The objective of the study was to investigate and determine the appropriate way of producing quality and accurate gears most economically through the use of a circle as a substitute to involute profile in gear cutting. Two different gears of same dimensional characteristics were cut; one using a Computer Numerical Control machine utilizing circle profile and the other using conventional milling machine. Dimensional comparisons were made of the two cut gears against an actual involute profile to determine the margin of error. The circle involute profile made using CNC was found to be exactly as the true involute profile though an error of 0.078 mm was observed in some sections of the profile. For the hobbing case, it was impossible to accurately machine the actual depth and as such, the intended depth of 7.32 was surpassed by 0.2 mm. The tooth was thicker throughout the length of the profile and the fillet radii lacked homogeneity. The involute circle approach was therefore successful and as such can benefit all CNC users and gear cutters in producing accurate gears cheaply.

**Key words:** Circle profile, CNC machine, form gear cutters, involute profile

### INTRODUCTION

In industry, gears are used to transmit power and motion between machine parts and many applications such as; industrial gear reducers, automobile engines, and household appliances. The involute gear profile is the most commonly used curve for gearing today. To construct an involute of a curve a taut string is replaced by a line segment that is tangent to the curve on one end, while the other end traces out the involute. The length of the line segment is changed by an amount equal to the arc length that is traversed on the curve as the tangent point is moved along the curve (Tavakoli and Houser, 1985)

The traditional method of machining these gears has been by use of form cutters that are normally bought off-the-shelf and one cutter can be used repeatedly in machining many similar gears provided they are of the same module (Wei, 2004). Often times, only one gear may be required to be machined and as such buying a gear cutter for that purpose only is not economical. Another limitation of form cutters is their availability since hardwares cannot stock all types of form cutters available in engineering design. With advancement in technology, a shift from conventional machining to CAD/CAM has been realized and in most CAD/CAM systems a cutting path has to be generated so long as it can be expressed

mathematically (Smith, 1993). A circle involute curve thus needs research into ways of simply approximating the circle involute to a circle using any CAD systems. The circle can now be expressed mathematically and can be read by a CAM system as such machine can cut a gear without the use of form cutter as in conventional gear cutting.

### MATERIALS AND METHODS

**Design:** Gear design has never been taken seriously and no consideration is given to such things as correct involute profile, tooth thickness, root fillet and surface finish (Reyes *et al.*, 2008). In this research each part of gear was designed to detail from first principles.

The dimensional data which is required to make a gear drawing can be broken down into blank dimensions and tooth data. Pinion dimensions were selected with consideration to acceptable design values (Oberg *et al.*, 1996), these were: Module ( $m$ ) = 3.5, Pressure angle ( $\theta$ ) = 20° Number of teeth ( $N$ ) = 22, Outside diameter ( $D_o$ ) = 84 mm, Pitch diameter ( $D$ ) = 77 mm, Base diameter ( $D_B$ ) = 72.356 mm, Circular pitch  $P$  = 10.9956, Circular tooth thickness ( $t$ ) = 4.4978 mm, Chordal tooth thickness ( $t_c$ ) = 5.49 mm, this is found using geometrical applications, Backlash allowance ( $b_l$ ) = 0.1 mm, from

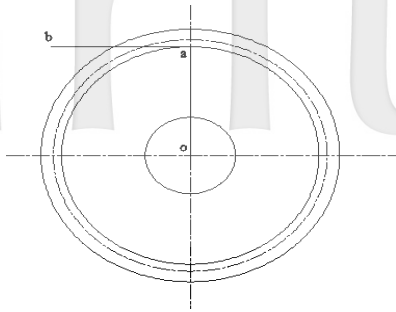

Fig. 1: Circle and perpendicular lines

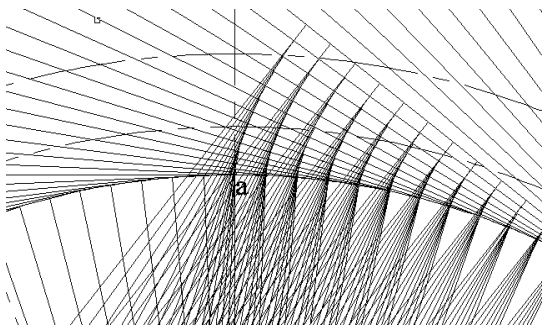

Fig. 2: Array of perpendicular and tangential lines

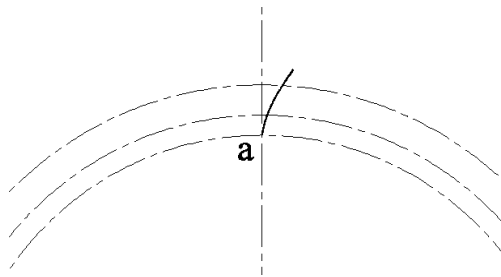

Fig. 3: True involute profile

ANSI standards, Effective Chordal length 5.3931 mm, Clearance (c) = 0.875 mm, Fillet radius (f) = 1.0500 mm.

The CAD drawings were done at Moi University computer labs and machining done at Kenya Ordnance Factories Corporation Workshop between the period January to July 2011. Using Computer Aided Design (CAD) software, a spur gear was designed from first principles. The circle involute profile was generated. This generated circle involute was then used using convenient method by CAD drafting to generate a circle involute profile of the desired gear. The approximating circle needs not be one but can be a combination of many circles provided that they join seamlessly.

**CAD drawing:** Using Autocad a base circle diameter, pitch circle diameter and outside diameter (84 mm) were drawn. Two lines oa and ab were also drawn, (Fig. 1).

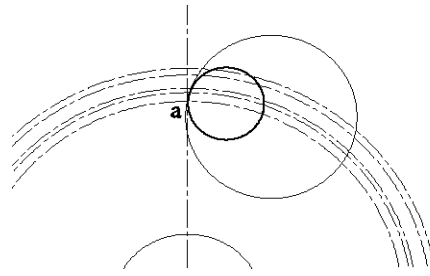

Fig. 4: Approximation of true involute profile

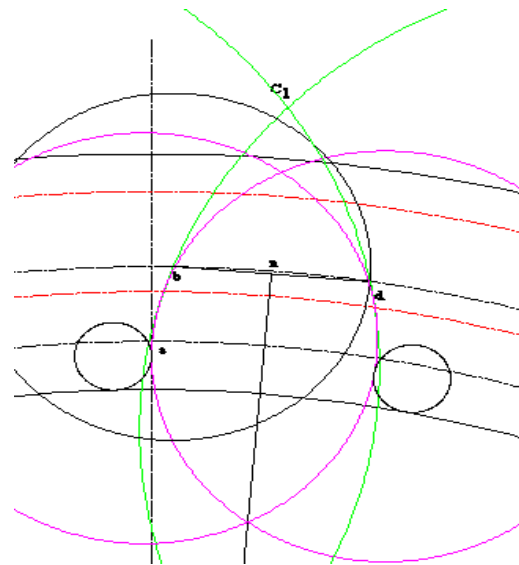

Fig. 5: Mirror of approximated circle involute

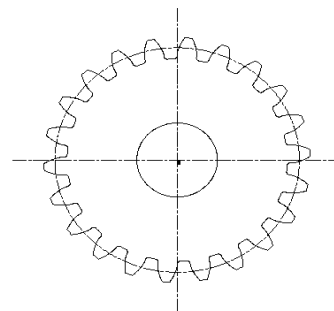

Fig. 6: Polar command to generate complete gear

The two lines were copied radially using point 0 as the centre point to produce 150 copies. Using the offset command of CAD, points of the involute curve were determined. Starting from point (a) as first point of the involute, the second point is when the tangent line of length equal to  $1/150^{\text{th}}$  of the base circle circumference ie  $227.3141 \div 150 = 1.5154$  mm. The length of the 2<sup>nd</sup> tangential line will be  $1 \times 1.5154$  mm, 3<sup>rd</sup> is  $2 \times 1.5154$  and so forth to the 16<sup>th</sup> line, (Fig. 2).

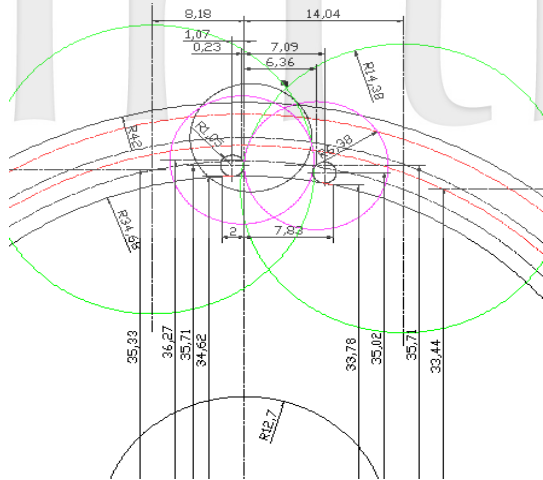

Fig. 7: Pinion tooth detail dimensions

The polyline command was then used to join the points to come up with the required involute profile, (Fig. 3).

To get the approximate circle to the involute line, it should be noted that there are three critical points that the circle must pass through in the involute so as to make the approximation as close as possible, (Fig. 4). The first point is where the involute intersects the pitch circle and the second and the third is where the involute intersects 2/3 addendum and 1/3 dedendum heights respectively from the pitch circle diameter. Using the mirror command, the other tooth profile was generated then applying the polar command the rest of the 22 teeth were copied as depicted in Fig. 5 and 6.

One of the tooth is dimensioned to detail as shown in Fig. 7.

**Gear cutting:**

**CNC machine:** After designs were made using CAD, one of the tooth was dimensioned in detail as shown in Fig. 7. From this drawing a single tooth macro-program was generated:

**Single tooth macro-program:**

Points in this context is denoted as P  
 $P_1(x = 0, y = 0)$  which is the centre of the work piece to be machined.

Plotting of the circles making up the gear tooth

Circle  $C_1$  R55.28

Circle  $C_2$  R62.8

Circle  $C_3$  ( $x = -3.71, y = 56.08$ ) and  $R = 10.01$

Circle  $C_4$  ( $x = 9.98, y = 55.31$ ) and  $R = 10.01$

Circle  $C_5$  ( $x = -14.55, y = 54.21$ ) and  $R = 21$

Circle  $C_6$  ( $x = 20.54, y = 52.23$ ) and  $R = 21$

Circle  $C_7$  ( $x = 7.24, y = 55.75$ ) and  $R = 0.94$

Circle  $C_8$  ( $x = -0.94, y = 56.21$ ) and  $R = 56.21$

Number of teeth = 38

Angle of rotation =  $360/38 = 9.47$

Number of times = 38

**Cutting path:**

$P_2(x = -2, y = 55.28)$

$P_3 = (C1 \& C8)$

$P_4 = (C6 \& C8)$

$P_5 = (C2 \& C6)$

$P_6 = (C2 \& C7)$

$P_7 = (C5 \& C7)$

$P_8 = (C1 \& C7)$

$P_9(x = 8.19, y = 55.28)$

Press END to save as macro-programme.

Rotate what is in the macro-programme 22 times.

This marks the end of APT.

This program was used by the machine in Fig. 8 to cut the gear.



Fig. 8: CNC wire cut machine



Fig. 9: Hobbing/milling machine

**Milling machine:** The same gear was cut using the conventional method of gear hobbing, arrangement shown in Fig. 9.

**Profile of CNC cut gear:** The circle involute profile of this gear was found to be exactly as the true involute profile though error of 0.06 mm was observed in some sections of the profile (Fig. 11).

### RESULTS AND DISCUSSION

**Profile:** Measurement of an involute profile is based on its geometric property (A line normal to an involute curve is a tangent to the base circle) (Peter, 2002). The actual involute profile of the spur gear was drawn on a transparent plastic paper with a magnification of x10. The gear was then placed on the table of the profile and projected on the screen under a magnification of x10 using a profile projector shown in Fig. 10. The gear was then checked for consistency with the actual involute profile printed on the plastic paper.



Fig. 11: profile of CNC cut gear



Fig. 10: Profile projector

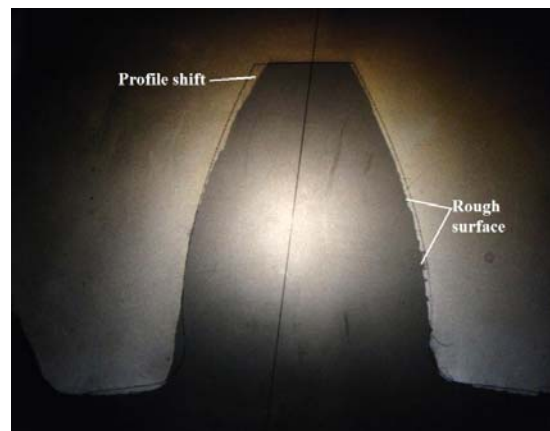

Fig. 12: Profile of milled/hobbed gear

Table 1: Tooth thickness comparison

Vertical distance where measurement is taken	Actual involute measurement	Milled gear		CNC cut gear	
		Measurement	Deviation	Measurement	Deviation
0.2	2.56	2.27	- 0.29	2.50	- 0.06
1.0	3.38	3.36	- 0.02	3.37	- 0.01
2.0	4.28	4.32	+ 0.04	4.29	+ 0.01
3.0	5.02	5.13	+ 0.11	5.03	+ 0.01
4.0	5.62	5.79	+ 0.17	5.61	- 0.01
5.0	6.02	6.33	+ 0.31	6.02	0.00
5.8	6.16	6.47	+ 0.31	6.14	- 0.02

Table 2: Comparison of roughness level

	Milled/hobbed gear (µm)	CNC cut gear (µm)
Addendum roughness level	1.1615	1.232
Dedendum roughness level	1.417	1.242
Average	1.516	1.237



Fig. 15: Roughness testing measuring machine

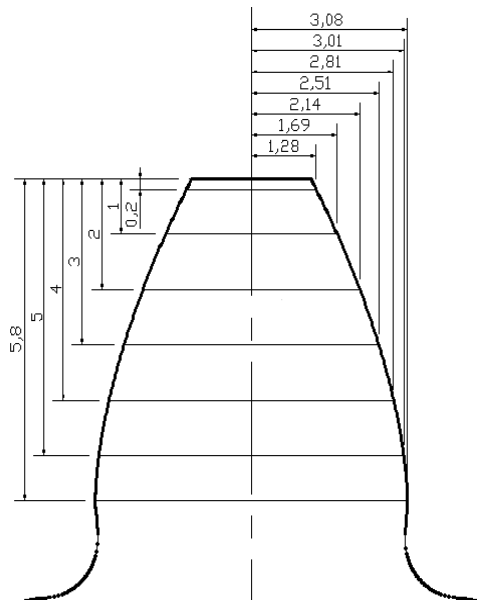

Fig. 14: Graph of tooth thickness comparison. All dimensions in mm

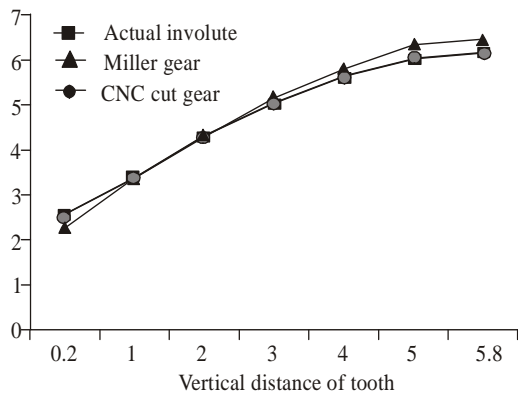

Fig. 13: Dimensions of the actual involute profile

**Profile of milled/hobbed gear:**

**Profile of design:** At the tip of the tooth there was a profile shift to the left side only, this gave the impression that this is an asymmetric tooth, Fig. 12. At the region of the addendum, an inward profile shift was noted, which had an effect of reducing the top landing of the tooth drastically. During hobbing, it was impossible to accurately machine actual depth and the intended depth of 7.32 mm and as such, was surpassed by 0.2 mm. The tooth was thinner at the tip but thicker towards the root, the fillet radiuses lacked homogeneity.

**Profile dimensional measurement:** Using profile projector the dimensions of the two machined gears were measured and compared with those of the actual involute profile, Fig. 13.

To get to compare the values of the machined against what is expected, the two machined gears were measured using a profile projector. The tip of the tooth was taken as the datum, then the vertical reading set to allow for the desired horizontal measurement to be read and recorded. This process was repeated till all the seven measurements got as shown in the table below, Table 1. It should be noted that for the CNC machined gear, the deviations are within the allowable backlash allowance of 0.1 mm while for the milled is not within. The graph in Fig. 14 shows that tooth dimensional thickness for a milled gear is thinner at the addendum and thicker at the dedendum. The

CNC cut gear has got very minimum dimensional deviations.

**Surface roughness:** The roughness level of the two gears was measured using a roughness measuring machine, Fig.15. Two points along the gear profile at the addendum and the dedendum were measured and the average worked out, Table 2.

The average roughness level Ra was found to be 1.516  $\mu\text{m}$  for the milled gear and 1.237  $\mu\text{m}$  for the CNC cut gear.

### CONCLUSION

- This research identified the use of a circle in gear cutting as accurate, cheap and faster method as compared to the conventional hobbing. The cost of gear cutting by CNC was found to be less than that of hobbing by approximately 17%. This was attributed to less setup time, less production time and low power consumption.
- On projecting the gear under magnification of x10 the CNC cut gear tooth thickness error was -0.06 mm which is within the standard backlash gear allowance of -0.11 mm. As for the case of hobbed gear, it was thinner at the tip of the tooth by upto -0.29 mm and thicker from the pitch circle to the root by upto 0.31 mm, in both cases the error was way beyond the allowable backlash of -0.1 mm. Tooth thickness error causes excess or reduced backlash between the mating gears. Reduced backlash causes binding while excessive error causes loss of tooth strength.
- In normal practice of gear cutting by hobbing, one gear cutter is used to cut a range of number of teeth per gear like from 35 to 54 numbers of teeth. Given this big range the compromise will be error in tooth profile. During generation of involute profile using CAD it was observed that each gear has its own unique involute profile which is dependent on blank diameter and number of teeth, as such, no two blanks with different dimensions can share a gear cutter. As was observed in one of the tooth that there was a tendency for the thickness to reduce at the tip. This is because the involute curve tends to shift inwards as the number of teeth reduces, thus reducing the base circle.
- This anomaly of not getting the right profile of gear explains the reason why gear cutting is a big challenge in developing countries. Original gears from manufactures last over 10 years, these gears are rarely found off-the-shelf in hardware stores. When they are replaced by machining from the local workshops, one is sure that this replacement shall be as frequently as once or twice yearly, because the

gear produced has totally different dimensional values from the original.

- The experiments also showed that CNC cut gear was of finer surface finish as compared to the milled/hobbed gear which had a higher roughness level. A finer surface finish is desired in gear surface to reduce wear, noise and non uniform motion transmission. Rougher surfaces causes pitting in gear systems.

### RECOMMENDATIONS

The project has identified the use of circle in gear cutting as a substitute to involute profile. Further studies and investigation are recommended to find out:

- Faster way of generating the involute profile should be obtained.
- Further research should be done to investigate the use of circle in cutting other types of gears.
- Research into ways of custom making a gear cutter for hobbing to take care of situations where milling machine must be used.
- Gear cutters to adapt the use of the proposed method circle as opposed to involute profile so as to increase the service life of gears to as close as possible like the original.

### ACKNOWLEDGMENT

The authors acknowledge the financial support provided by Kenya Ordnance Factories Corporation.

### REFERENCES

- Oberg, E., D.J. Franklin, L.H. Holbrook and H.R. Henry, 1996. Source machinery's handbook by Industrial Press Inc., New York.
- Reyes, O., A. Rebolledo and G. Sanchez, 2008. Proceedings of the World Congress on Engineering, London, vol. 2 WCE.
- Smith, G.T., 1993. CNC machining technology volume III: part programming techniques, Technology Research Centre, Southampton Institute, City Campus, East Park Terraces, Southampton SO9 4WW, UK.
- Tavakoli, M.S. and D.R. Houser, 1985. Optimum profile modifications of static transmission errors of spur gears. ASME J. Mech. Transmiss. Automat. Design, 107: 529-535.
- Wei, Z., T. Li-Ping, L. Li-Zhi and W. Fang-Xiang, 2011. Nonlinear model-based method for clustering periodically expressed genes. Sci. World J., 11: 2051-2061.