

# Comparing Reflexive and Object marking in Lubukusu

Justine M. Sikuku, Moi University

*In this paper I compare reflexive and object marking in Lubukusu, and show that the two elements display both similarities and differences in their morphological and syntactic patterning. It is for example notable that in simple transitive sentences, the two affixes occur between the tense marking morpheme and the verb stem and are normally in complementary distribution. In addition, both the RFM and OM occur in class 15 nominals, are doublable with a left dislocated DP, and are used with passives. On the basis of such similarities, I conclude that the affixes represent a similar syntactic category characterized as an incorporated pronominal element. On the other hand, I show that there are a number of differences between the two forms which include the fact that the RFM occurs in class 5 nominals, while the OM is disallowed in such contexts, the RFM is possible with another RFM on the same verb whereas only one OM is allowed on a verb at any given time. I argue that such differences support the thesis that the RFM and the OM attach to different positions in the syntactic derivation, with the RFM occurring lower than the OM.*

## 1. Introduction

Lubukusu (Bantu, Western Kenya) marks the reflexive and the object as affixes on the verb, as shown in (1) and (2), respectively. Interestingly, these affixes usually occupy a similar morphological position to the left of the verb root, after the TAM markers, and are therefore in complementary distribution.<sup>1</sup>

- 1) Wekesa a-a-**i**-siim-a  
Wekesa SM.1-PST-RFM-like-fv  
*Wekesa likes himself*
- 2) Wekesa a-a-**mu**-siim-a  
Wekesa SM.1-PST-OM-like-fv  
*Wekesa likes him*

As a result, the two forms are often regarded as representing a similar syntactic category. In Bantu literature, this category is identified as either an agreement affix, in languages such as Kinande (Baker 2008), Sambia (Riedel 2009), Zulu (Buell 2005), or an incorporated pronominal clitic, as in Lubukusu (Diercks and Sikuku 2011), and Chichewa (Mchombo 2001, 2002, 2004). The most central basis of such a distinction is whether or not the OM can be doubled with an in situ lexical NP. If doubling is allowed, then OM is agreement, with the doubled NP assuming argument status. Conversely, if doubling is not possible, the OM is probably pronominal. Both properties are attested in a number of Bantu languages; see Marten et al (2007) and Riedel (2009) a detailed cross Bantu overview.

I take a slightly different approach in this paper. Whereas it is true that the OM has received greater attention, the trend has always been to tag along the RFM and unify it with the OM, in the process obscuring otherwise significant characteristics that may result if close attention

---

\* I acknowledge NSF grant BCS-0919086, awarded to the Afranaph Project, Ken Safir, PI. I thank Mark Baker, Ken Safir, Michael Diercks, and Michael Marlo for their comments and support. Thanks also to participants at WOCAL 7 at the University of Buea, Cameroon for their input. Any errors of fact or interpretation remain my responsibility.

1 Abbreviations used in the glosses include: APPL, applicative; CAUS, causative; cX, noun class X (X ranging from 1 to 23); FUT, future; fv, final vowel; LOC, locative; NEG, negation; OM, object marker; PASS, passive; PST, past; RFM, reflexive marker; RCM, reciprocal marker; SM, subject marker; TAM, tense, aspect, mode; TNS, tense; VE, verb extensions.

was paid to each of these markers separately. For a unified analysis, see, for example, Harjula (2004:127), Mchombo (1993), and Meeussen (1967). I argue for separation, and show that a systematic comparison of the two affixes reveals both similarities and differences. The similarities include complementarity in distribution, especially in simple transitive verbs, with each other and with an NP in situ, and shared morphological position, between the tense affix and verb root. On the other hand, the differences arise in several contexts, especially that of co-occurrence. It is for example notable that, whereas the OM cannot occur with another OM or RCM, the RFM more often co-occurs with an OM, a RCM, and even another RFM.

On the basis of such comparison, I conclude that the many similarities between the OM and RFM in Lubukusu follow from them being incorporated pronouns, and the differences are as a result of the two affixes incorporating into different functional heads; see Buell (2005), Muriungi (2008), and Marlo (2012) for a distinct treatment of OM/RFM in Zulu, Tharaka, and selected Bantu languages, respectively.

In order to lay the foundation for the analysis, I examine, in section 2, previous studies on reflexive and object marking, particularly in Bantu. Section 3 discusses the expression of reflexive and object marking in Lubukusu, and makes a comparison between the RFM and OM, while highlighting the similarities and differences. Section 4 presents the theoretical analysis proposed while Section 5 concludes the paper.

## 2. Reflexive and Object Marking in Bantu

Studies in Bantu morphosyntax have paid considerable attention to a comparison of similar structures in different languages. Some of these structures include the OM and the RFM which form a significant part of Bantu literature; See, for example, Duranti 1979, Bresnan and Moshi 1990, Alsina and Mchombo 1993, Rugemalira 1993, Henderson 2006, Baker 2008, Diercks and Sikuku 2011 (henceforth D&S). Nevertheless, a casual look reveals that such studies have greatly been skewed in favor of the OM, as compared to the RFM. Infact some of them explicitly state that the RFM is one of the OMs (Harjula (2004:127), Mchombo (1993), and Meeussen (1967)), and as noted by Marlo (2012), some, such as Beaudoin-Lietz et al (2004:85) openly exclude the RFM, while some are quite implicit. In this paper, I argue that a better understanding of the RFM and OM in Bantu can only be realized if the two forms are compared systematically.

Most Bantu languages mark the object and the reflexive as a prefix on the verb, often occurring in a fixed position on the verbal template as shown in (3), along the lines of Nurse and Philipson (2003), and exemplified in (4) with Swahili data.<sup>2</sup>

### 3) Bantu Verb Template

NEG	SM	TAM	OM/RFM	VERB	VE	TAM	FV/MODE	LOC/NEG
1	2	3	4	5	6	7	8	9

### 4) Ha-tu-ta-m-pig-i-a Kiboko

NEG(1)-SM.1pl(2)-TNS(3)-OM.c1(4)-beat(5)-APPL(6)-fv(8) whip  
*We shall not beat him with a whip*

<sup>2</sup> The ability by any given language to select a given number of elements in the template at once is a language specific parameter. There are those languages like Swahili which do not allow all the elements, while languages like Lubukusu can have all the nine on a single verb; *Se-ba-li-ba-siim-isy-ang-a ta.* (they will not be pleasing them)

Following Beaudoin-Lietz et al (2004), object marking in Bantu triggers a three way categorization of Bantu languages. Type 1 languages use object prefixes only, Type 2 use suffixes, while Type 3 have both prefixes and suffixes. Lubukusu would fall under Type 3 languages, as it has object prefixes, as shown in (1) and (2), and a host of locative suffixes, which can also be analyzed as OMs; see Diercks (2011) for a detailed analysis of locative clitics in Lubukusu. In this paper I focus entirely on the prefixes mainly because of their fairly unchangeable status as incorporated pronouns. The locative markers, on the other hand, are much more fluid making their analysis more challenging, as they shift status from being argument structures to non-argument ones.

Unlike Beaudoin-Lietz et al (*Op cit*), Marten, et al (2007), Marten and Kula (2012) and Riedel (2009) use a number of parameters for OMs to characterize a cross section of Bantu languages according to whether or not they conform to such parameters. The parameters, framed in question form, include; Can the object marker and the lexical object NP co-occur?; Is co-occurrence of object marker and object NP required in some contexts?; Are there locative object markers?; Is object marking restricted to one object marker per verb?; Is the order of multiple object markers structurally restricted?; Can either benefactive or theme objects be expressed by an object marker?; Is an object marker required/optional/disallowed in object relatives?

These parameters are quite significant in so far as they make it possible for linguists, especially those working in Bantu, to discover fine grained morphosyntactic variations and/or similarities in Bantu object marking. In all these studies, however, nothing is said about the RFM, which as we have already mentioned, forms a significant part of verbal morphology in general and object marking in particular. In this research I use some of the parameters outlined to compare the OM and RFM.

D&S give a first formal description of the OM in Lubukusu. Using properties of OMs formally outlined by Henderson (2006), Marten, Kula, and Thwala (2007), and developed by Riedel (2009), in her comparison of Sambia and selected Bantu languages, in addition to more diagnostics, D&S argue for the treatment of Lubukusu OM as an incorporated pronoun, similar to Bresnan and Mchombo (1987), Mchombo (1984, 2004) for Chichewa, and Storoshenko (2009) for Shona. This analysis contrasts with Riedel (2009) who argues for an agreement analysis. The main argument in D&S is hinged on the following properties of the OM in Lubukusu:<sup>3</sup>

- a) The OM cannot co-occur with an in-situ lexical NP, in any context.
- b) The OM is disallowed in object relatives.
- c) The OM cannot occur with a clefted object.
- d) The OM cannot occur with a WH phrase.
- e) Only one OM is allowed in a clause at any given time.

D&S also give a brief comparison of RFM with OM, mainly on the basis of variation in noun class properties depending on referent (OM shows such variation, while RFM does not), nominalization contexts where both are allowed with class 15 *khu-* nominals, and their complementarity with mono-transitive verbs. This comparison is only used to support the view that both affixes are incorporated pronominals. It is however noted that the RFM&OM may co-occur if the verb is multi-transitive. On the other hand, OM+OM combination is disallowed, contrary to expectations if the two affixes are treated as being similar. This means

---

<sup>3</sup> There is evidence in Lubukusu indicating that for properties (b) and (c), the OM is possible if it is contained in a deeply embedded clause.

that something must be said about the RFM that licenses such a distribution. In this paper, I argue that this can only be possible if the RFM attaches to a different head.

Storoshenko (2009) discusses the status of the Shona (Bantu) reflexive marker by using different tests to determine whether it is a valence operator or an OM. Three sets of tests are used: The first set is replicated from Kioko (2005) on Kikamba (Bantu, Kenya). The second considers Lidz (1996) universals of reflexives, and lastly, a comparison is made with Xhosa and Tswana facts on object marking.

According to Kioko, the first source of evidence for regarding the RFM as an OM is based on the morphological position of the RFM between tense marking and the verb root, a position also occupied by the OM. This is apparently attested in Shona.<sup>4</sup>

- 5) Ka-rume ka-ka-zvi-pis-a  
C12-man SM.c12-PST-RFM-burn-fv  
*The bad man burned himself* (Storoshenko 2009:42)

As already demonstrated in (1) and (2), Lubukusu also shows this property which is the starting point to the claim that the RFM and OM are related syntactic categories.

Secondly, it is shown that OM+NP doubling is present in both Kikamba and Shona, and although the conclusion appears confusing, it is used as evidence for regarding the OM as pronominal, and consequently, the results are extended to the RFM, as in (6) below.

- 6) ?Shingi a-ka-zvi-bik-a Shingi  
Shingi SM-PST-RFM-cook-fv Shingi  
*Shingi cooked herself, Shingi*

RFM+NP doubling is unacceptable in Lubukusu, and indeed, even in Shona, the acceptability judgment is downgraded, casting doubts on the reliability of such a test for the RFM. Nevertheless, contrary to Storoshenko's assertion, I argue that the doubling facts provide one of the solid challenges to the incorporation analysis which require a clear justification if the analysis is to be maintained. I attempt to do this in the paper.

Finally according to Kioko, the RFM triggers final vowel 'e' in imperatives just as the OM does contrary to the conventional 'a'. A result that apparently justifies similar treatment for the two elements. This pattern is also attested in Shona.

- 7) Zvi-gez-e  
RFM-wash-fv  
*Wash yourself*

This diagnostic however triggers the opposite result in Lubukusu where a reflexive marked verb has final 'a' just like a normal verb whereas the OM triggers final 'e', as in (10). Consequently it may sound logical to treat the two elements as being distinct categories. On the contrary, I argue that this difference may be used to account for their syntactic position. Because the RFM does not change the structure of the verb, then its position should be closer to the verb than the OM which triggers a final vowel change.<sup>5</sup>

- 8a) I-sing-a  
RFM-wash-fv  
*Wash yourself*

---

<sup>4</sup> The glossing in Storoshenko have been modified to fit the format used in this paper.

<sup>5</sup> This argument is related to Polak (1983) and Marlo (2010) regarding certain object prefixes (mainly RFM and 1sg) being more integrated into the phonology/morphology of the verb stem than others.

- b) mu-sing-e  
 OM-wash-fv  
*Wash him*

Storeshenko also outlines some universals of reflexives following Lidz (1995). It is for example noted that cross linguistically, verbal reflexives seem to have broader functions than simple reflexives. They are for example used in decausatives and in possessive forms. Whereas the Shona RFM does not show such characteristics, in Lubukusu, it is common for the reflexive to co-occur with an object which is in a possessive relationship with the subject regardless of the fact that the host verb may be a two argument verb as in (9).

- 9a) Wekesa a-a-i-rem-a ku-mu-khono  
 Wekesa SM.c1-PST-RFM-cut-fv c3-c3-hand  
*Wekesa cut his own hand*
- b) Wekesa a-a-mu-rem-a ku-mu-khono  
 Wekesa SM.c1-PST-RFM-cut-fv c3-c3-hand  
*Wekesa cut his hand*

In such cases, the possesum must be the subject's body part. The possessive function is also true for the OM which, unlike the RFM, is the possessor of the body part object (9b). Such facts seem to point to a cross linguistic generalization that adds to the understanding of reflexivity not only in Lubukusu, but also in other languages.

### 3. The structure of Reflexive and Object marking in Lubukusu

The OM in Lubukusu, like in most other Bantu languages is hosted by a transitive verb, usually in complementary distribution with, an in-situ overt object NP (except when such an NP is a pronoun or a strong discourse topic). Its position is typically between the tense marker and the verb stem. Its form is mainly determined by the noun class that it corresponds to. This is shown in the table below using the verb for 'hit' in the simple past tense.

Class	OM	Example: 'hit' <i>-pa</i>
1	mu-	ba-a- <b>mu</b> -pa 'They hit him/her.'
2	ba-	ba-a- <b>ba</b> -pa 'They hit them.' ( <i>animate</i> )
3	ku-	ba-a- <b>ku</b> -pa 'They hit it.'
4	ki-	ba-a- <b>ki</b> -pa 'They hit them.' ( <i>non-human</i> )
5	li-	ba-a- <b>li</b> -pa 'They hit it.'
6	ka-	ba-a- <b>ka</b> -pa 'They hit them.' ( <i>non-human</i> )
7	si-	ba-a- <b>si</b> -pa 'They hit it.'
8	bi-	ba-a- <b>bi</b> -pa 'They hit them.' ( <i>non-human</i> )
9	ki-	ba-a- <b>ki</b> -pa 'They hit it.'
10	chi-	ba-a- <b>chi</b> -pa 'They hit them.' ( <i>non-human</i> )
11	lu-	Ba-a- <b>lu</b> -pa 'They hit it'
12	Kha-	Ba-a- <b>kha</b> -pa 'They hit it'
14	Bu-	Ba-a- <b>bu</b> -pa 'They hit it' (abstract noun)
15	-	*ba-a- <b>khu</b> -pa 'they hit it' (infinitive)
16	-Kho	Ba-a-pa- <b>kho</b> 'They hit on it' (locative)
17a	-o	Ba-a-pa- <b>o</b> 'They hit there' (locative)
b	-yo	Ba-a-pa- <b>yo</b> 'They hit there' (locative)
18	-mo	Ba-a-pa- <b>mo</b> 'They hit in there' (locative)
19	Ku-	Ba-a- <b>ku</b> -pa 'They hit it- (Augmentative)
23	-yo	Ba-a-pa- <b>yo</b> 'They hit there' (locative)

I have included the locative markers for the locative classes to show that such classes do not usually take the conventional OM, in the pre-verbal position; instead they have a post verbal locative clitic. Notice also that class 15 does not have a corresponding object marker, perhaps pointing to its non-nominal characteristics.

The realization of the RFM in Lubukusu is through prefixation reminiscent of many Bantu languages. The form *-i-* is the default RFM, sometimes occurring as *-e-*, or with a preceding or following glide, in phonologically defined environments<sup>6</sup>.

10) Yohana a-a-**i**-bon-a

John SM-PST-RFM-saw-fv

*John saw himself*

11) N-**i**-siing-ang-a

1sgSM-RFM-wash-Asp-fv

*I wash myself*

12) Khu- khu-**i**-inyusy-a khu-eewe khu-li khu-a kalaa

C15-c15-RFM-stand-fv c15-his c15-be c15-of slow

*His (way of) raising himself is slow*

In rapid speech, the RFM in (10) surfaces as ‘e’. In (11) and (12), it remains ‘i’ with the latter being preceded by a glide, and occurs as *khukhwiinyusya*. Notice also that the doubling of class 15 affix is motivated by the initial vowel on the verb stem. Generally, the RFM is realized as ‘e’ when preceded by ‘a’, and ‘i’ in all other environments.

### 3.0 The Reflexive marker and Object marker compared

In this section, I compare the RFM and the OM noting both similarities and differences between the two elements, and their implications to the main hypothesis of the paper: Like the OM, the RFM can also be analyzed as an incorporated pronominal element.

#### 3.1 Similarities

In the literature, the OM and RFM are usually considered to be the same. This view is justifiable for a variety of shared characteristics. First, both are realized as prefixes between the tense affix and the root verb.

13) Wekesa a-a-**i**-siim-a

Wekesa SM.1-PST-RFM-like-fv

*Wekesa likes himself*

14) Wekesa a-a-**mu**-siim-a

Wekesa SM.1-PST-OM-like-fv

*Wekesa likes him*

In simple transitive verbs, the two forms appear to represent the same argument and are therefore in complementary distribution. Again, the elements, on their own, seem to fully satisfy the verb’s argument structure, and as a result they are analyzed as pronominal arguments. If this argument is to be sustained, then it should predict that the RFM and OM cannot co-occur with an in-situ lexical DP. It turns out that this prediction is true as shown in (15).

15a) Sitawa a-a-tiil-a **o-mu-aana**

Sitawa SM.1-Pst-hold-fv c1-c1-child

*Sitawa held the child.*

---

<sup>6</sup> Glides are mainly used to break vowel clusters for ease of articulation.

- b) Sitawa a-a-**mu**-tiil-a (\***o-mu-aana**)  
 Sitawa SM.1-Pst-OM-hold-fv c1-c1-child  
*Sitawa held him, (the child)*
- c) Sitawa a-a-**i**-tiil-a (\***o-mu-aana**)  
 Sitawa SM.1-Pst-RFM-hold-fv c1-c1-child  
*Sitawa held herself, (the child)*

The idea is that since the OM and RFM can replace the lexical DP, then they are pronominal, and are simply incorporated in the verb's morphology through a combination of some form of A-movement and incorporation. The basic idea is that since the RFM and OM are generated in [V, DP] position, a full DP in the same position is excluded to avoid competition for the same argument slot. The details of this kind of D movement are discussed in section 4.<sup>7</sup>

Perhaps more problematic for an incorporation based theory is the fourth characteristic which allows the RFM/OM to co-occur only with a pronominal NP, typically, ni-Agr for the OM, and Agr-eene for the RFM.

- 16) Wekesa a-a-**i**-siim-a **o-mu-eene**  
 Wekesa SM.1-Pst-RFM-like-fv c1-c1-own  
*Wekesa likes himself*
- 17) Wekesa a-a-**mu**-siim-a **ni-ye**  
 Wekesa SM.1-Pst-OM1-like-fv Foc-him  
*Wekesa likes him*

Such doubling facts seem to undermine the incorporation analysis. However, on the contrary, I argue that since doubling is only possible with pronouns (and is optional), the same movement that leads to incorporation (leaving behind a trace in VP internal position) can be used to account for the doubling facts. The idea is to maintain the same operation that results in either the OM alone or co-occurrence. The difference will then only be seen during spell-out. I assume that the trace left behind after D movement is optionally pronounced at PF, not as an OM but as a pronominal element. This kind of analysis is related to the *big DP hypothesis* of Uriagereka (1995). Apparently following Torego (1995), Uriagereka proposes that in certain Western Romance languages where clitics co-occur with a full NP, both elements are generated inside the same DP, with the clitic as the D head and the doubled NP as the specifier (or complement in other analyses e.g Kramer (2011), Bax & Diercks (2012)). It is this doubled NP that is spelled out as a pronoun in Lubukusu.

The fifth similarity is concerned with the infinitive class 15 nominals. It is shown that both elements are allowed in such contexts.

- 18a) Khu-**mu**-siim-a khu-li khu-layi  
 C15-OM.1-like-fv SM.c15-be c15-good  
*Praising him is good*
- b) Khu-khu-**i**-siim-a khu-li khu-layi  
 C15-c15-RFM-like-fv SM.c15-be c15-good  
*Praising oneself is good*

As will be shown in section 4.2, class 15 nominals behave more like verbs in so far as they can pattern with the conventional verb categories such as the OM. More so, the possibility of

---

<sup>7</sup> Doubling of the OM and with a lexical DP is possible in cases where the object DP is highly topicalized, sometimes marked by a separate tone unit or distinct punctuation. (16b) can then become acceptable if *omwaana* is topicalized.

having the RFM in a similar context points to a unified analysis, where such categories favor a pronominal analysis.<sup>8</sup>

The sixth characteristic relates to relative clauses and clefting, which are commonly used as a diagnostic in Bantu to determine the status of some verbal affixes. The diagnostic is first attributed to Herderson (2006) who argues that Bantu languages that allow doubling of an OM and a moved overt object NP in relative clauses and cleft constructions have object agreement whereas those that do not allow such doubling have pronominal object marking. Whereas it is impossible to test the RFM in object relative clauses, the OM in Lubukusu is usually ruled out of such contexts apparently because of its pronominal status, as noted by D&S, and shown in (20) below.

- 19) Wekesa a-a-soma [ sii-tabu ni-syo n-a-(\*si)-kula \_\_\_ ] (D&S)  
 Wekesa 1SM-PST-read 7-book COMP-7 1sgSM-PST-(\*OM7)-buy  
*Wekesa read the book which I bought.*

In clefted object NPs, both the OM and RFM are impossible, again pointing to their pronominal status. The idea is that since an object has been moved to the clause initial position via clefting, it is predictable that having an argument on the theta role assigning verb corresponding to the clefted one will yield undesirable results. This turns out to be the case as shown in (20) and (21).

- 20) o-mu-eene ni-ye ni-ye Wekesa a-a-(\*i)-okesi-a si-tabu  
 c1-c1-own FOC-c1FOC-c1Wekesa SM.c1.1s-PST-RFM-show-fv c7-book  
*It is himself that Wekesa (self)-showed the book.*

- 21) Wafula ni-ye ni-ye Wekesa a-a-(\*mu)-okesi-a si-tabu  
 Wafula FOC-c1FOC-c1Wekesa SM.c1.1s-PST-RFM-show-fv c7-book  
*It is Wafula that Wekesa showed the book.*

The simplest and most natural conclusion that can be made from such facts is that the OM is an incorporated pronominal element occupying a full argument position. Consequently, if this is acceptable for the OM, then it should apply to the RFM. The significant piece of evidence being that doubling them with a clefted object results in an undesirable conflict. It is worth noting that if the theme object in (30) is a pronoun like *niye*, then doubling is possible though not surprising given (19) above.

Again with such facts in mind one can predict that if the two elements are pronominal, then they can co-occur with a non-argument DP that is base generated in VP external position because there will be no competition for argument status. True to this prediction, both the RFM and OM can and must co-occur with a dislocated DP.

- 22) a. Mayi a-siima ba-ba-ana  
 1mother 1SM-like 2-2-children  
*The mother likes the children.*  
 b. Babaana, mayi a-\*(ba)-siima  
 2-2-children 1mother 1SM-\*(2OM)-like  
*The children, the mother likes them.*  
 23) o-mu-eene Wekesa a-a-\*(i)-okesi-a si-tabu  
 c1-c1-own Wekesa SM.c1-PST-RFM-show-fv c7-book  
*Himself, Wekesa (self)-showed the book. (Left dislocation, w/RFM)*

<sup>8</sup> See Baker, Safir and Sikuku (2012) for details on different types of clauses including khu- and li-nominals, and how they pattern in terms of their nominal/verbal properties.



These results therefore extend some of the facts known about the OM to the RFM and give an empirically supported conclusion that because the RFM occurs in conventional object position, is in complementary distribution with the OM, and an in-situ lexical DP (except when it is a pronoun), can occur in infinitive clauses, is ruled out in object cleft constructions, and must occur in a verb whose object is left dislocated, then it should be analyzed as an incorporated anaphor. In addition the similarities are easy to analyze, and are sufficient enough to support the conclusion made. The conclusion however faces a serious challenge when we consider the differences between the OM and the RFM. In the face of support largely coming from the similarities between the two elements, it is expected that the differences could as well undermine such gains. I turn to this apparent dilemma in the next section.

### 3.2 Differences

It is expected that the differences between the OM and RFM should be problematic for an incorporation analysis. In this section, I argue that contrary to expectation, such differences help to refine the pronominal analysis showing that instead of the OM and RFM competing for a similar position in the syntactic derivation, they attach to distinct functional heads; the former to the accusative licensing F<sub>acc</sub>, while the latter to a voice head, which is incidentally lower in the structure, as is shown in (xx).

First, it is notable that the RFM is allowed with the *li*-nominals while the OM is not as shown in (24a,b) respectively. This follows from the fact that *li*-nominals tend to be more nominal than they are verbal.

- 24a) Li-li-i-siim-isy-a li-li li-lume  
 c5-c5-RFM-please-Caus-fv SM.c5-be c5-difficult  
*Pleasing oneself is difficult*
- b) Li-(\*mu)-siim-isy-a li-li li-lume  
 c5-c1.OM-please-Caus-fv SM.c5-be c5-difficult  
*Pleasing him is difficult*

Following (Alexiadou 2001, 2009, 2010), nominalization is analyzed differently depending on the functional heads that it allows. The nature and status of such functional heads is systematically determined by the nature of the nominalization in question. If we assume that nominalization varies according to whether or not it is more verbal than it is nominal then it is expected that ‘verbal’ nominalization will have the ability to select conventional verbal arguments such as the bare object DP or OM (Alexiadou 2001), while the less verbal ones will be limited in the selection. It is noticeable that this difference accounts for the difference between *khu*- and *li*- nominals in Lubukusu, and by extension, their ability to select the OM and RFM.

In the analysis proposed in section 4, the OM attaches to an accusative functional head, while the RFM as a voice projection similar to the RCM attaches to a corresponding voice head. In addition *khu*-clauses usually allow aspectual markers, in line with their verbal nature. The habitual marker *-ang-* can, for example, be added to the structure in (18) to form (25) below.

- 25) Khu-mu-siim-ang-a khu-li khu-layi  
 c15-c1.OM-like-HAB-fv SM.c15-be c15-good  
*To always like him is good*

In the literature, the standard measure of how verbal a nominal clause is, normally relates to its ability to take a bare object or adverbial modification (Chomsky 1970, Alexiadou 2001). This is possible for *khu*- but it is ruled out for *li*-, as shown in (26) and (27) respectively.

- 26) Khu-tim-a bwangu khu-a-mu-yeet-a  
 C15-run-fv fast SM.c15-PST-OM.c1-help-fv  
*Running fast helped him*
- 27) Li-tim-a (\*bwangu) li-a-mu-yeet-a  
 C5-run-fv fast SM.c5-PST-OM.c1-help-fv  
*(The) running fast helped him*

Another point of deviation relates to the fact that both the OM and RFM trigger varied possibilities of co-occurrence when each is doubled or is combined with the other. First, RFM+RFM combination is possible in clauses with a ditransitive verb, either lexically realized or with one of the valence increasing affixes.

- 28) Khalayi a-a-**i-i**-siim-isy-a  
 Khalayi SM.1-Pst-RFM-RFM-like-Caus-fv  
*Khalayi made herself like herself*

This perhaps presents one of the strongest arguments for stipulating that the RFM attaches to a different head from the OM, but it is still an incorporated anaphor, as it independently satisfies the verb's argument structure. The doubling of the RFM and not the OM may be as a result of a language specific restriction that only allows one OM per verb, but has no problem if the doubled elements are those attaching to voice heads or are themselves voice heads such as the reciprocal or passive. In order to make this assumption hold, it ought to be possible to combine more than one of such heads, and as shown in (29), this is possible with RCM+RCM, and RFM+RCM.

- 29a) Ba-ba-ana ba-a-siim-an-isy-an-a  
 C2-c2-child SM.c2-PST-like-RCM-CAUS-RCM-fv  
*The children made each other to like each other*
- b) Ba-ba-ana ba-a-e-siim-an-isy-a  
 C2-c2-child SM.c2-PST-RFM-like-RCM-CAUS-fv  
*The children made themselves like each other*

In addition, the OM+RFM combination is also predicted and is shown in (30) to be possible.

- 30) Khalayi a-a-**mu-i**-siim-isy-a  
 Khalayi SM.1-Pst-OM.1-RFM-like-Caus-fv  
*Khalayi made him like herself*

However, as expected, OM+OM combination is unacceptable.

- 31) \*Wamalwa a-**mu-ba**-siim-isy-a  
 Wamalwa SM.1-OM.1-OM.2-cook-APP-fv  
*Wamalwa made him like them*

From such combination possibilities, one can conclude that although Lubukusu does not allow more than one OM in a clause, exceptions are found where the combination involves either two voice heads or a voice head and an OM.

Passive and double object contexts also provide interesting distinctions with regard to OM and RFM occurrence. This is best seen in ditransitive verbs, which trigger a two way distinction depending on whether there is symmetrical or asymmetrical relation between the two objects of the verb. It is also notable that animacy, and perhaps person features come into play in trying to compute the distinction.

32) Wafula a-a-okesi-a Wekesa si-tabu  
Wafula SM.c1-PST-show-fv Wekesa c7-book  
*Wafula showed Wekesa a book*

33) Wafula a-a-okesi-a Wekesa o-mu-aana  
Wafula SM.c1-PST-show-fv Wekesa c1-c1-child  
*Wafula showed Wekesa a child or Wafula showed a child Wekesa*

Whereas *Wekesa* in (32) can only be the goal, in (33) it can also be the theme because of animacy. The two objects can see as opposed to the inanimate 'book' in (32). This extends to a context where an OM is used.

34a) Wafula a-a-**mu**-okesi-a si-tabu  
Wafula SM.c1-PST-OM-show-fv c7-book  
*Wafula showed him a book*

b) Wafula a-a-**si**-okesi-a Wekesa  
Wafula SM.c1-PST-OM-show-fv Wekesa  
*Wafula showed Wekesa it (\*Wafula showed it Wekesa)*

With an inanimate object as the theme, it does not matter whether it is the theme or goal that is object marked, because the interpretation remains the same. Compare this with (35) below.

35) Wafula a-a-**mu**-okesi-a Wekesa  
Wafula SM.c1-PST-c1.OM-show-fv Wekesa  
*Wafula showed him Wekesa or Wafula showed Wekesa him*

Here, *Wekesa* can either be the theme or goal depending on intended interpretation. This contrasts with the RFM, (and 1<sup>st</sup> and 2<sup>nd</sup> person OM) which can only express the goal.

36) Wafula a-a-**i**-okesi-a Wekesa  
Wafula SM.c1-PST-RFM-show-fv Wekesa  
*Wafula showed himself Wekesa (\*Wafula showed Wekesa himself)*

37) Wafula a-a-n-(c)okesy-a Wekesa  
Wafula SM.c1-PST-1<sup>st</sup>.OM-show-fv Wekesa  
*Wafula showed me Wekesa (\*Wafula showed me to Wekesa)*

It therefore means that the OM is symmetrical while the RFM and 1<sup>st</sup> and 2<sup>nd</sup> person OMs are asymmetrical. This distinction raises an important question as to why two sets of elements analyzed as being similar, can pattern differently in DOC. I argue that this difference is taken as further evidence for the analysis adopted in this paper. First, the fact that the RFM behaves like the 1<sup>st</sup> and 2<sup>nd</sup> person OM provides proof that it can be analyzed as a pronominal element. Secondly, the difference with the 3<sup>rd</sup> person OM can be explained by independent factors. In order to compute these factors, I hypothesize that there must be something present in the RFM/1<sup>st</sup> and 2<sup>nd</sup> forms that groups them together as opposed to the 3<sup>rd</sup> person form. If we assume that this feature has to do with dependence, then the RFM/ 1<sup>st</sup> and 2<sup>nd</sup> person pronouns should be more dependent than 3<sup>rd</sup> person OM, hence require to be closer to the verb than the less dependent forms. In DOC, the goal is always closer than the theme, hence the prediction that the RFM should be asymmetrical. These facts however change when an applicative is used (see BS&S for details on (a)symmetry in DOC). I examine what happens in passive contexts next.

- 38a) E-m-bwa ya-a-nch-okesy-ebw-a.  
 C9-c9-dog SM.c9-PST-1sOM-show-PASS-FV  
*The dog was shown to me.*
- b) Wekesa a-a-mu-okesy-ebw-a.  
 Wekesa SM.c1-PST-c1.OM-show-PASS-FV  
*Wekesa was shown to him (??Wekesa caused him to be shown)*
- c) Wekesa a-a-e-okesy-ebw-a  
 Wekesa SM.c1-PST-RFM-show-PASS-fv  
*Wekesa was shown to himself*

Whereas (38a) and (c) are not ambiguous i.e. the 1<sup>st</sup> person OM and RFM represent the goal argument, the OM in (b) is generally ambiguous with regard to the argument that it represents. Whereas the goal is the most natural interpretation available, the theme can also be represented by the OM, though marginally. This is not quite surprising given the (a)symmetry facts already noted for the 3<sup>rd</sup> vs RFM/1<sup>st</sup> and 2<sup>nd</sup> person OM.

#### 4. Determiner Incorporation and Incorporated Anaphor: The analysis

As already noted, the analysis used in this paper makes the thesis that both the OM and RFM are incorporated pronominal elements, a conclusion supported by the similarities between the two elements. On the other hand the differences provide enough evidence for us to believe that the RFM targets a different kind of head from that of the OM. Consequently, this shows that the difference between the RFM and OM is only derivational. The immediate consequence of such an account would be that the whole process of incorporation takes place independent of the binding relations.

In order to account for the OM/RFM facts, I develop an analysis similar to Baker, Safir & Sikuku (2012) (BS&S) schematized in (39) below.

39)

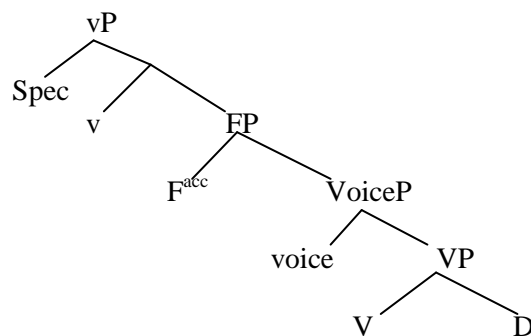

This structure captures the facts in simple transitive verbs where the functional categories FP and VoiceP are both available, but because they are in complementary distribution, only one is used at any given time. The possibility of co occurrence is also left open, and as shown in (30) OM/RFM co occurrence is possible in Lubukusu. In this analysis, the OM targets the higher (F<sup>acc</sup>) FC whereas the RFM targets the lower voice head, on an assumption that this theory does not distinguish between active and other types of voice heads. Following D&S, on the basis of Matushansky (2006), I assume the existence of two operations that help to explain the RFM/OM facts. First, I content that there is D movement to [Spec vP] via a relevant functional head, followed by M-merger of the D head into the v resulting in a verbal complex. These twin operations are what constitute incorporation, and are shown in (40a, b) below.

40a)

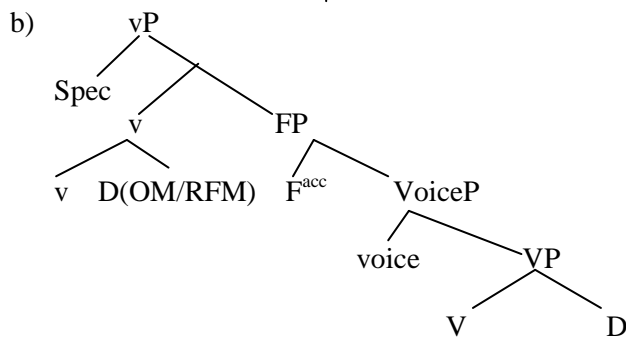
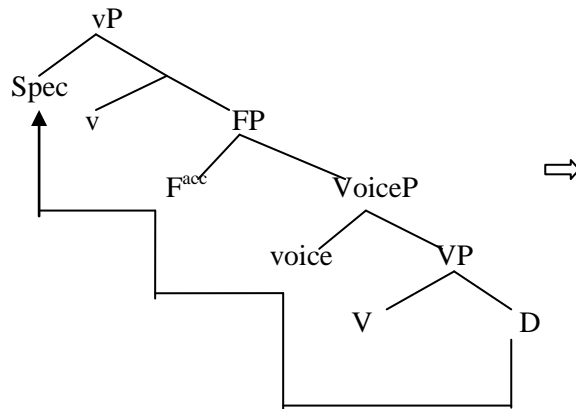

## 5.0 Conclusion

In this paper, I have argued that the RFM is the same as the OM, because both are analyzed as incorporated arguments whenever they share empirical similarities. On the other hand, the differences provide evidence that the RFM is a voice marker just like the RCM and passive, occupying a position slightly lower than the F head associated with OM. Morphological ordering is part of the evidence for this assumption. The evidence discussed to support this position is summarized in the table below.

### 5.1 Properties of RFM and OM

	Properties	RFM	OM
1.	Realized between tense and verbroot	√	√
2.	Replace an in-situ DP	√	√
3.	Doubleable with in-situ pronoun	√	√
4.	Occur in <i>khu-</i> nominals	√	√
5.	Realized in object relative clauses	N/A	√
6.	Occurs with clefted object NP	×	×
7.	Occur with <i>wh-</i> clefts	N/A	×
8.	Occur with a left dislocated DP	√	√
9.	Allowed with <i>li-</i> nominals	√	×
10.	Occur with RFM	√	√
11.	Occur with OM	√	×
12.	Used with Passives	√	√

## References

- Alexiadou, Artemis. 2010. Nominalizations: a probe into the architecture of grammar. *Language and Linguistics Compass* 4: 496-523.
- Alexiadou, Artemis (2009) On the role of syntactic locality in morphological processes: the case of (Greek) derived nominals. In A. Giannakidou & M. Rathert (eds.) *Quantification, Definiteness and Nominalization*. Oxford: Oxford University Press, 253-280.
- Alexiadou, Artemis. 2001. *Functional Structure in Nominals: Nominalization and ergativity*. Amsterdam: John Benjamins.
- Alsina, Alex and Mchombo, Sam. 1993. Object Asymmetries and the Chichewa Applicative Construction. In Sam Mchombo, ed. *Theoretical Aspects of Bantu Grammar*, 17-45 Stanford: CSLI Publications.
- Baker, Mark. 2008. *The Syntax of Agreement and Concord*. Cambridge: Cambridge University Press.
- Baker, Mark, Safi, Ken & Sikuku, Justine. 2012. Sources of (A)symmetry in Bantu Double Object Constructions. In the *Proceedings of the 30<sup>th</sup> Western Coast Conference on Formal Linguistics*. 54-64. Cascadilla Proceedings Project.
- Baker, Mark, Safir, Ken & Sikuku, Justine. 2012. On the Categories of Clausal Constituents in Lubukusu and Limits to their Selection. Paper under review at the Journal for African Languages and Linguistics (JALL).
- Baker, Mark, and Collins, Chris. 2006. Linkers and the internal structure of vP. *Natural Language and Linguistic Theory* 24:307-354.
- Bax, Anna and Diercks, Michael. 2012. Out with the New, in with the Old: Topic based Object Marking in Manyika. To appear in SALALS.
- Beaudoin-Lietz, Christa, Nurse, Derek and Sarah Rose. 2004. Pronominal Object Marking in Bantu. In Akinbiyi Akinlabi and Oluseye Adesola. eds. *Proceedings of the 4<sup>th</sup> World Congress on African Linguistics*. 175-188. Cologne: Rudiger Koppe.
- Bowers, John. 2010. *Arguments as Relations. Linguistic Inquiry Monographs* 58. MIT Press
- Bresnan, Joan and Moshi, Lioba. 1990. Object Asymmetries in Comparative Bantu Syntax. *Linguistic Inquiry* 21:147-185
- Bresnan, Joan and Mchombo, Sam. 1987. Topic, Pronoun and Agreement in Chichewa. *Language*. 63: 741-782.
- Buell, Leston. 2005. Issues in Zulu Verbal Morphosyntax. UCLA Dissertation.
- Chomsky, Noam. 1970. Remarks on nominalization. In Roderick Jacobs and Peter Rosenbaum, eds. *Readings in English transformational grammar*, 184-221. Waltham, MA: Blaisdell.
- Diercks, Michael. 2011b. The Morphosyntax of Lubukusu Locative Inversion and the Parameterization of Agree. *Lingua* 125(125): 702-720.
- Diercks, Michael and Sikuku, Justine. 2011. Object marking as pronominal incorporation in Lubukusu. ms. Pomona College and Moi University.
- Duranti, Alessandro. 1979. Object Clitic Pronouns in Bantu and the Topicality Hierarchy. *Studies in African Linguistics* X: 31-45.

- Harjula, Lotta. 2004. *The Ha Language of Tanzania*. Cologne: Rudiger Koppe.
- Henderson, Brent. 2006. The Syntax and Typology of Bantu relative clauses. University of Illinois at Urbana Champaign Dissertation.
- Kioko, Angelina Nduku. 2005. *Theoretical Issues in the Grammar of Kikamba*. Munich: Lincom Europa
- Kramer, Ruth. 2011. Clitic Doubling or Object Agreement: An Amharic Investigation.
- Lidz, Jeffrey. 1995. On the Non-Existence of Reflexive Clitics. *Papers from the 31st Regional Meeting of the Chicago Linguistics Society*. The Parasession on Clitics. 181-198.
- Marlo, Michael. 2012. On the Number of Object Prefixes in Bantu Languages. Ms. University of Missouri.
- Marlo, Michael. 2011. Prefix Stem Fusion In Bantu. Ms. University of Missouri.
- Marten, Lutz & Nancy C. Kula. 2012. Object marking and morpho-syntactic variation in Bantu. To appear in SALALS.
- Marten, Lutz and Kula, C. and Thwala, N. 2007. Parameters of Morphosyntactic Variation in Bantu. *Transactions of the Philological Society*, 105 (3): 253-338.
- Matushansky, Ora. 2006. Head Movement in Linguistic Theory. *Linguistic Inquiry* 37(1): 69-109
- Mchombo, Sam. 2004. *The syntax of Chichewa*. Cambridge: Cambridge University Press.
- Mchombo, Sam. 2002. Affixes, clitics and Bantu morphosyntax. In Amberber, Mengistu & Peter Collins. eds. *Language Universals and Variation. Perspectives on Cognitive Science 3*. Westport, CT: Praeger. 185-210
- Mchombo, Sam. ed. 1993. *Theoretical Aspects of Bantu Grammar*. Stanford: CSLI Publication
- Meeussen, Achille Emiel. 1967. Bantu Grammatical Reconstructions. *Africana Linguistica III*. 79-121.
- Muriungi, Peter. 2008. Phrasal Movement inside Bantu Verbs: Deriving Affix Scope and Order in Kiitharaka. University of Tromso Dissertation.
- Nurse, Derek and Phillipson, Gerard. eds. 2003. *The Bantu Language*. London: Routledge.
- Riedel, Kristina. 2009. The syntax of Object Marking in Sambia: A Comparative Bantu Perspective. Leiden University Dissertation.
- Rugemalira, Joshat. 1993a. Bantu Multiple 'object' Constructions. *Linguistic Analysis*. 23:226-252
- Safir, Ken and Justine Sikuku. 2011. Lubukusu Anaphora Sketch. Afranaph Project, Ken Safir, ed. <http://www.africananaphora.rutgers.edu/images/stories/downloads/casefiles/lubukusu-as-3.1.pdf>.
- Sikuku, Justine Mukhwana. 2011. Syntactic patterns of anaphoric relations in Lubukusu: Representation and interpretation in a minimalist perspective. University of Nairobi Dissertation.
- Storoshenko R. Dennis. 2009. Investigating the Shona Reflexive *zvi*. *Selected Proceedings of the 39<sup>th</sup> Annual Conference on African Linguistics*. 42-56. Cascadilla Proceedings Project.
- Torego, Esther. 1995. From Argument to Non-Argument Pronouns: Spanish Doubled

Reflexives. *Probus* 7:21-241.

Uriagereka, Juan.1995. Aspects of the Syntax of Clitic Placement in Western Romance.  
*Linguistic Inquiry* 26:79-124